



## Recommended Attachment Techniques for Opti-Cap® and Milli-Cap® Capacitors

rev 0.

### 1. Recommended mounting method of the Opti-Cap® to soft or hard substrate using conductive epoxy.

Mounting Recommendations to achieve design performance:

- Bottom surface of the Opti-Cap®, is to always be in direct contact with the circuit trace.
- Reflections will be minimized when a 50Ω micro-strip line width is approximately .020" to .025" (.508 - .635mm).
- The break in the micro-strip should be in the range of .015" - .020" (.308 - .508mm).
- The maximum processing temperatures is +150°C for non-solderable versions.

#### A. Deposit Conductive Epoxy:

1. Place a single conductive epoxy drop on each micro-strip as illustrated; the edge of the epoxy shall be at least .003" - .004" (.076 - .102 mm) back from the edge of the trace to prevent filling the gap with epoxy.
2. Each epoxy dot shall be approximately .010" - .015" (.254 - .381mm) in diameter and .003" - .005" (.076 - .127 mm) thick. Note: A 1 mil (.0254mm) high epoxy dot will typically result in a pad 10 mils by 15 mils (.254mm x .381mm).

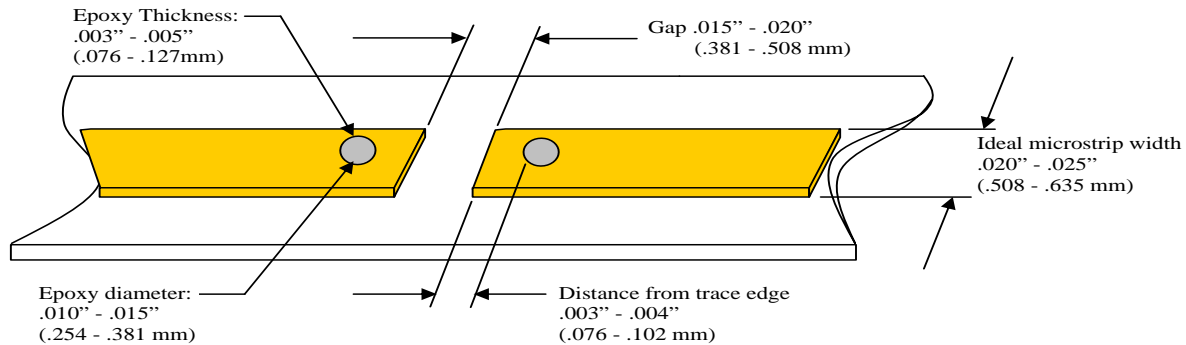

#### B. Perform Opti-Cap® Attachment:

1. The Opti-Cap® shall be placed on the micro-strip Milli-Cap® down.
2. Alignment of the Opti-Cap® is best performed by aligning the Milli-Cap® to the trace:
  - Center the Milli-Cap® length to the gap in the trace.
  - Center the Milli-Cap® width to the trace width.
  - The Milli-Cap® terminations (end caps) shall fall within the individual epoxy drop on each trace.
  - Use even pressure to make connection.

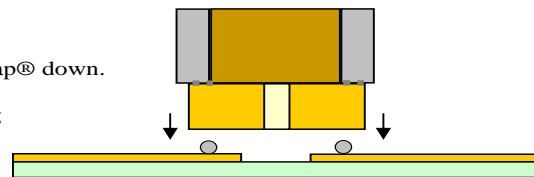

#### C. Cure Epoxy:

- Typical Epoxy such as Ablebond 84-1 LMI by ABLESTIK
- Cure According to Manufacturer's Preferred Schedule.
- Typically 125°C to 150°C max

#### Dielectric Laboratories Inc.

2777 Route 20 East, Cazenovia, NY 13035-9477  
 Phone: 315-655-8710 Facsimile: 315-655-8179

e-mail: [sales@dilabs.com](mailto:sales@dilabs.com) web: <http://www.dilabs.com>

QUALITY SYSTEM ISO 9001 CERTIFIED/ENVIRONMENTAL SYSTEM ISO 14001 CERTIFIED



## Recommended Attachment Techniques for Opti-Cap® and Milli-Cap® Capacitors

rev 0.

### 2. Recommended mounting method of the Opti-Cap® to soft or hard substrate using solder.

Mounting Recommendations to achieve design performance:

- Bottom surface of the Opti-Cap®, is to always be in direct contact with the circuit trace.
- Reflections will be minimized when a 50Ω micro-strip line width is approximately .020" to .025" (.508 - .635mm).
- The break in the micro-strip should be in the range of .015" - .020" (.308 - .508mm).
- The maximum processing temperature +250°C for solderable versions.

#### A. Deposit Solder:

1. Place a single conductive solder drop on each micro-strip as illustrated; the edge of the solder shall be at least .001" - .002" (.025 - .051 mm) back from the edge of the trace to prevent filling the gap with solder.
2. Each solder drop shall be approximately .020" - .025" (.508 - .635mm) in diameter and .004" - .006" (.102 - .152mm) thick.

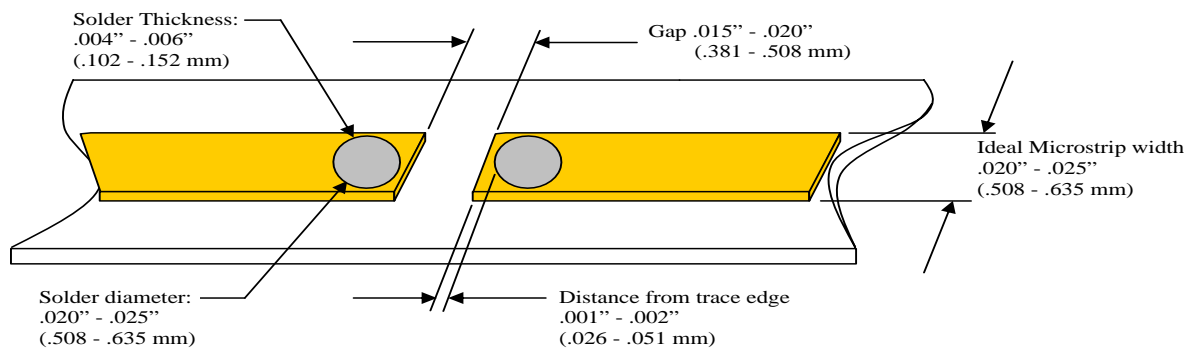

#### B. Perform Opti-Cap® Attachment:

1. The Opti-Cap® shall be placed on the micro-strip Milli-Cap® down.
2. Alignment of the Opti-Cap® is best performed by aligning the Milli-Cap® to the trace:
  - Center the Milli-Cap® length to the gap in trace.
  - Center the Milli-Cap® width to the trace width.
  - The Milli-Cap® terminations (end caps) shall fall within the individual solder drop on each trace.
  - Use even pressure to make connection.

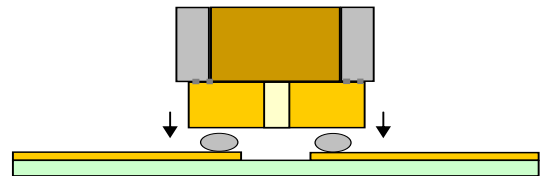

#### C. Reflow Solder:

- Typical solder such as SN62, SN63, etc.
- Reflow according to manufacturer's preferred cure schedule.
- Reflow temperature based on solder selected (not to exceed +250°C max.)
- After reflow, the solder fillet formed should be visible on exterior edges of Milli-Cap®.

#### Dielectric Laboratories Inc.

2777 Route 20 East, Cazenovia, NY 13035-9477

Phone: 315-655-8710 Facsimile: 315-655-8179

e-mail: [sales@dilabs.com](mailto:sales@dilabs.com)

web: <http://www.dilabs.com>

QUALITY SYSTEM ISO 9001 CERTIFIED/ENVIRONMENTAL SYSTEM ISO 14001 CERTIFIED