

### INTRODUCTION

This application note details the recommended minimum requirements of the software using a microcontroller for the control and data processing of all e2v technologies infrared gas sensors to obtain an indication of the target gas concentration (see Figure 1).

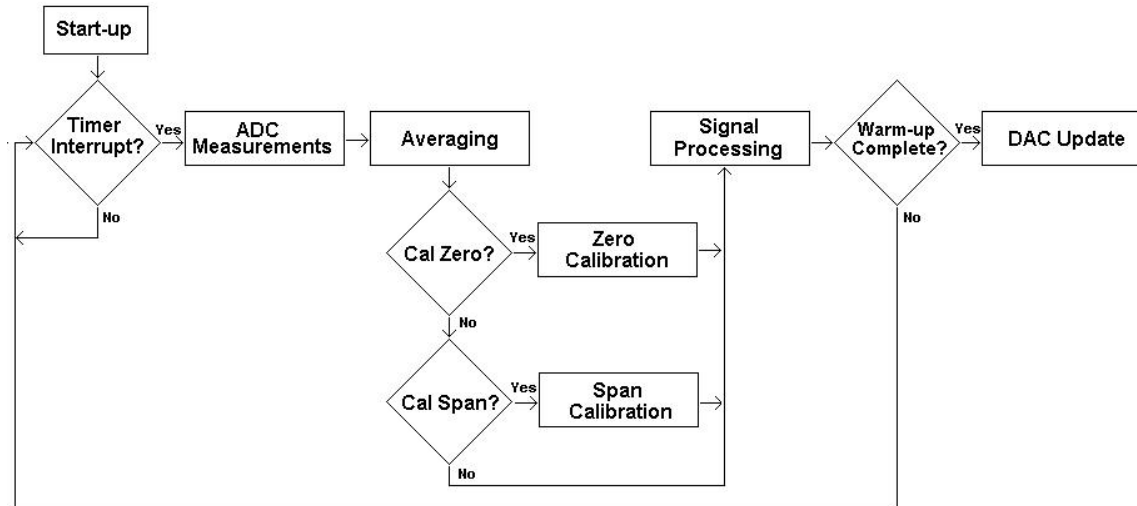

Figure 1 – Flow Diagram of Software Layout

Other possible requirements like RAM tests, ROM tests, watchdog timer, port set-up, function set-up and fault analysis are not considered as part of this application note and will be determined by the software engineer.

### START-UP ROUTINE

The following actions should be performed during the start-up routine:

- Lamp Interrupt Timer Set-up – To control the toggling of the lamp and collection of the detector voltages for a 4 Hz lamp pulse frequency. An interrupt needs to be generated every 125 ms to obtain a 4 Hz lamp pulse frequency.
- Load non-volatile memory information – Load the calibration (Zero, Span and Calibration Temperature) readings from non-volatile memory.
- Set “warm-up” timer to allow time for the sensor to stabilise after power-up, without setting the output (DAC) relating to the calculated concentration of the target gas.
- Set all ports to the required default settings (determined by software engineer).

### TIMER INTERRUPT

The system can remain idle until a lamp interrupt occurs (4 Hz).

## ADC MEASUREMENT ROUTINE

The ADC measurements should be taken at the maximum and minimum signal. Due to the response of the detector to changes in lamp status, the maximum and minimum signals will occur after a period of time from when the lamp changes state (see Figure 2).

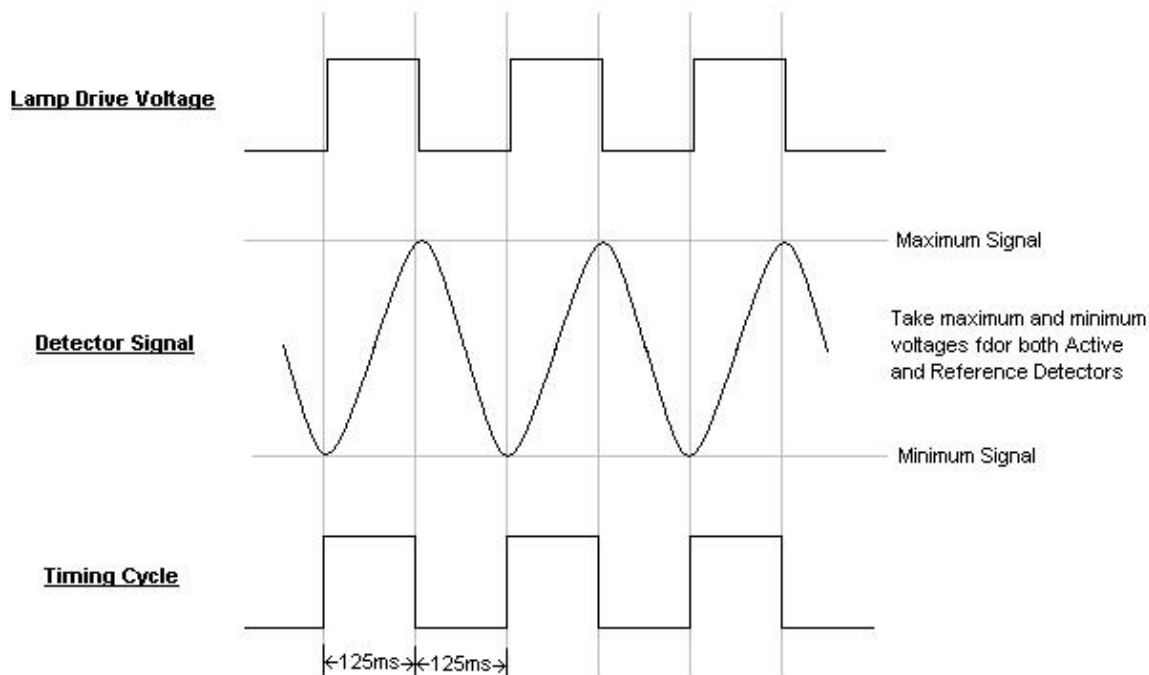

Figure 2 – Measurements in relation to the lamp drive voltage

## AVERAGING ROUTINE

The values of the amplified detector signals and temperature readings should be separately averaged, to reduce cycle-to-cycle noise further. This can be done digitally by maintaining a rolling average of the A-D converted maximum and minimum values of the outputs from both the active and reference detectors. A 16-fold rolling average should be sufficient to remove most noise without impinging on the response time of the sensors. Higher averaging may enable better low signal resolution at the expense of increases in response times. Another method is to take an average number of readings around the maximum and minimum signals. This forms an effective averaging method without compromising response times. The amount of averaging will be determined by the software engineer, based upon the required stability and response times.

## ZERO CALIBRATION ROUTINE

The zero calibration sequence shall be entered when triggered by the user (i.e. “zero” switch manually pressed on the hardware) and with the sensors exposed to a gas void of the target gas for a set time (enough time must be required to allow the sensor readings to stabilise and shall be determined by the software engineer).

Once triggered, calculate the calibration zero as detailed in Infrared Sensor Application Note 2 (Signal Processing for Infrared Gas Sensors), record the temperature (in kelvin) and save both readings in the non-volatile memory for use with all subsequent calculations to determine the target gas concentration.

## SPAN CALIBRATION ROUTINE

The span calibration sequence shall be entered when triggered by the user (i.e. “span” switch manually pressed on the hardware) and with the sensor exposed to the target gas at a predetermined concentration, for a set time (enough time must be required to allow the sensor readings to stabilise and shall be determined by the software engineer).

Once triggered, calculate the calibration span as detailed in Infrared Sensor Application Note 2 and save the reading in the non-volatile memory for use with all subsequent calculations to determine the target gas concentration.

## **SIGNAL PROCESSING ROUTINE**

Refer to Infrared Sensor Application Note 2.

## **DAC UPDATE ROUTINE**

This routine will be entered when an update of the output signal relating to the target gas concentration is required. This routine should only be entered when the warm-up period is complete (the output is normally set to a default relating to a target gas concentration of 0% during the start-up routine to avoid any potential alarm sounding during this period). The frequency of the DAC update shall be determined by the software engineer, with updates of up to one second considered normal.

Whilst e2v technologies has taken care to ensure the accuracy of the information contained herein it accepts no responsibility for the consequences of any use thereof and also reserves the right to change the specification of goods without notice. e2v technologies accepts no liability beyond the set out in its standard conditions of sale in respect of infringement of third party patents arising from the use of tubes or other devices in accordance with information contained herein.