



# Product Brief: JN5148 Advance Information

## ZigBee PRO and IEEE802.15.4 Wireless Microcontroller

### Overview

The JN5148 is an ultra low power, high performance wireless microcontroller targeted at ZigBee PRO networking applications. The device features an enhanced 32-bit RISC processor offering high coding efficiency through variable width instructions, a multi-stage instruction pipeline and low power operation with programmable clock speeds. It also includes a 2.4GHz IEEE802.15.4 compliant transceiver, 128kB of ROM, 128kB of RAM, and a rich mix of analogue and digital peripherals. The large memory footprint allows the device to run both the ZigBee PRO stack and an embedded application or in a co-processor mode. The operating current is below 18mA, allowing operation direct from a coin cell.

Enhanced peripherals include low power pulse counters running in sleep mode designed for pulse counting in AMR applications and a unique Time of Flight ranging engine, allowing accurate location services to be implemented on wireless sensor networks. It also includes a 4-wire I<sup>2</sup>S audio interface to interface directly to mainstream audio CODECs as well as conventional MCU peripherals.

### Block Diagram

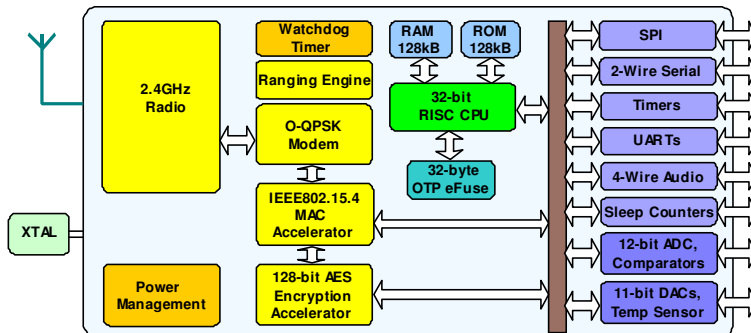

### Benefits

- Single chip integrates transceiver and microcontroller for wireless sensor networks
- Large memory footprint to run ZigBee PRO together with an application
- Very low current solution for long battery life
- Highly featured 32-bit RISC CPU for high performance and low power
- System BOM is low in component count and cost
- Extensive user peripherals

### Applications

- Robust and secure low power wireless applications
- ZigBee PRO networks
- Utilities metering (e.g. AMR)
- Home and commercial building automation
- Location Aware services - eg Asset Tracking
- Industrial systems
- Telemetry
- Remote Control
- Toys and gaming peripherals

### Features: Transceiver

- 2.4GHz IEEE802.15.4 compliant
- Time of Flight ranging engine
- 128-bit AES security processor
- MAC accelerator with packet formatting, CRCs, address check, auto-acks, timers
- 500 & 667kbps data rate modes
- Integrated sleep oscillator for low power
- On chip power regulation for 2.0V to 3.6V battery operation
- Deep sleep current 0.12µA
- Sleep current with active sleep timer 1.25µA
- <\$0.50 external component cost
- Rx current 18mA
- Tx current 15mA
- Receiver sensitivity -95dBm
- Transmit power 2.5dBm

### Features: Microcontroller

- 32-bit RISC CPU, 4 to 32MHz clock speed
- Low power operation
- Variable instruction width for high coding efficiency
- Multi-stage instruction pipeline
- 128kB ROM and 128kB RAM for bootloaded program code
- JTAG debug interface
- 4-input 12-bit ADC, 2 12-bit DACs, 2 comparators
- 3 application timer/counters
- 2 UARTs
- SPI port with 5 selects
- 2-wire serial interface
- 4-wire digital audio interface
- Watchdog timer and Power-on-Reset circuit
- Up to 21 DIO

**Industrial temp (-40°C to +85°C)**

**8x8mm 56-lead Sawn QFN**

Lead-free and RoHS compliant

# Jennic

## Battery Life Optimisation

To maximise battery life, the JN5148 supports a number of power management and sleep modes. These include ultra low power sleep modes and reduced CPU clock speeds down to 4MHz. Used effectively, these will allow a battery's life expectancy for a typical remote sensing application, to be of the order of a few years.

Power Saving Mode	Typical Current
Deep sleep	0.12µA
Sleep: wakeup on I/O or timer event	1.25µA
Sleep: wakeup on I/O or timer event and 128kB RAM retained	3.45µA

## Wireless Networking Protocol Stacks

The IEEE802.15.4 MAC and elements of the wireless networking stacks are included in the device ROM. The JN5148's combined memory footprint of 256kB and its efficient code usage ensure that it supports a full ZigBee PRO stack with sufficient code space to implement the application as well. Supported protocols include IEEE802.15.4 and ZigBee PRO, and in the future 6LoWPAN and Jennic's proprietary stack, JenNet. Custom ROM masks will support the integration of user code into ROM giving cost reduction for higher volume applications.

## Example Application Diagram

The JN5148 device requires a minimum of external components to support wireless applications; a crystal, serial flash memory, some decoupling components and printed antenna are all that is required for the lowest cost bill of materials and smallest size.

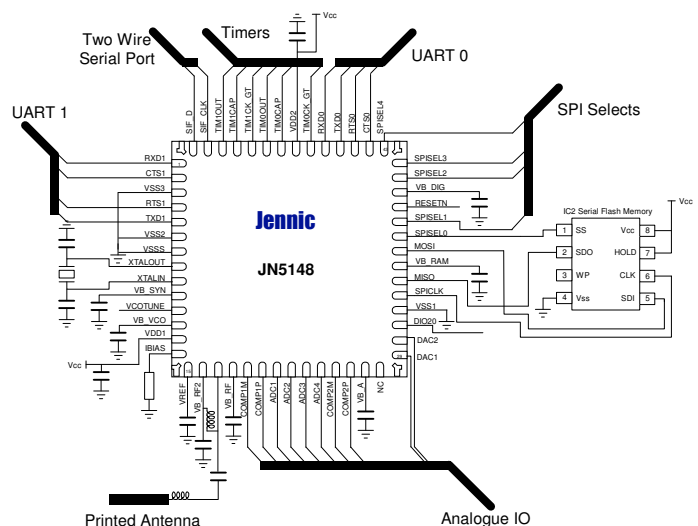

## Evaluation Kits

To assist users with the development of wireless sensor networks, Jennic provides a series of Evaluation Kits. These contain everything that is needed to carry out product development and test, and include controller and sensor boards and a Software Developer Kit (SDK).

The SDK provides a comprehensive suite of tools to facilitate the development of application code. The kit includes a C compiler, graphical and text debuggers, assembler, linker and flash programmer. Libraries are supplied for the supported network stacks, the chip peripheral interface and also a simple Application Programming Interface (API) to drive the peripherals on the controller and sensor boards. These, combined with the many example applications provided on the website, ensure that designers can take products to market easily and quickly.

**Jennic Ltd**  
 Furnival Street  
 Sheffield S1 4QT  
 United Kingdom

Tel: +44 (0)114 2812655  
 Fax: +44 (0)114 2812951  
 E-mail: [info@jennic.com](mailto:info@jennic.com)

[www.jennic.com](http://www.jennic.com)