



world leaders in the art of linear measurement

DZ Series

Datasheet
502782
Issue 3
EDCR 18450

Compact Digital Gauging Probes



Features

- ▶ 1mm and 2mm total measuring range
- ▶ Resolution programmable to $< 0.01\mu\text{m}$
- ▶ Simple installation and sensor change
- ▶ Excellent repeatability
- ▶ Very compact and robust
- ▶ Changeable tips
- ▶ Orbit digital
- ▶ IP65 Protection
- ▶ Traceable calibration

A novel approach to High Performance yet Compact Gauge Probes.

Description

The lack of space to fit a gauge probe is often a problem for gauge builders and test engineers alike. Very short pencil style gauge probes have usually meant a reduction in performance and/or life expectancy, but that has now changed.

Solartron Metrology has taken a novel but practical route to solving the problem of miniaturisation with strength to produce the DZ range of compact Gauge Probes.

Up to 50% reduction in length over conventional 1mm and 2mm gauge probes has been achieved yet performance and life expectancy has been maintained. due to a completely new approach to the construction of gauge probes.

The sensor in a gauge probe normally sits behind the bearing. A reduction in overall length of a gauge probe is normally achieved by reducing the size of the bearing, which in turn affects the life or accuracy of the probe. Solartron's novel approach of fitting a specially designed sensor inside a Ball Sleeve Bearing enables the gauge builder to install extremely compact probes without compromising on performance.

Mechanical outline

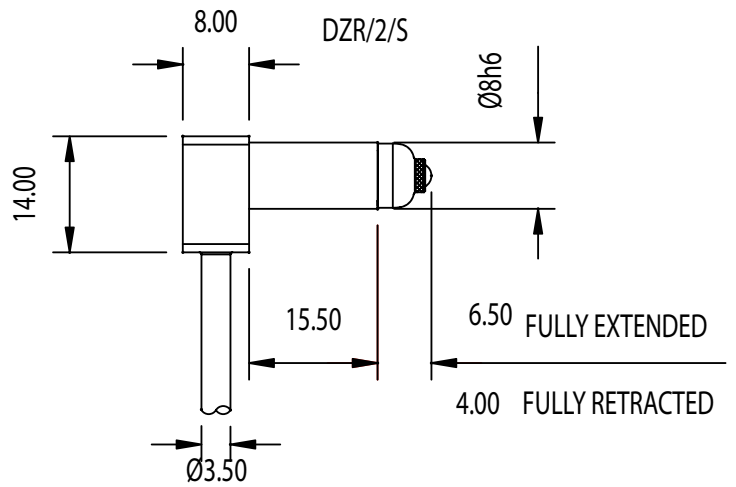
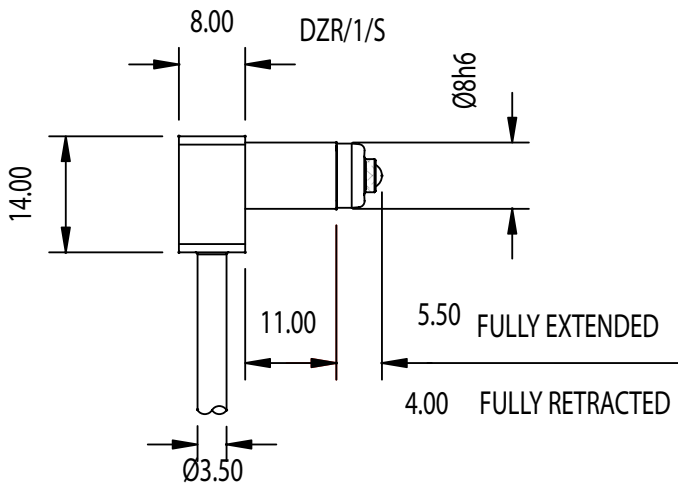
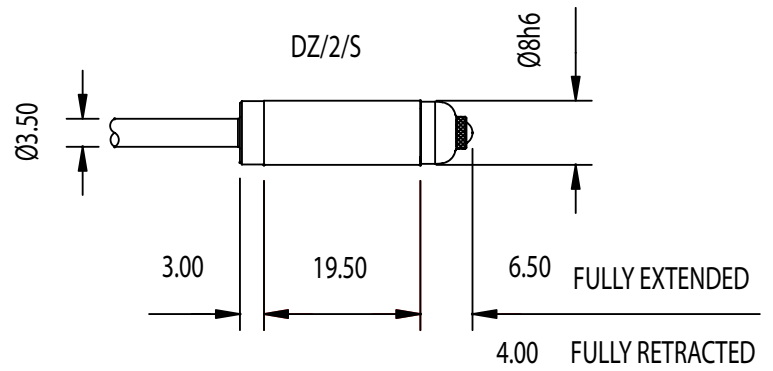
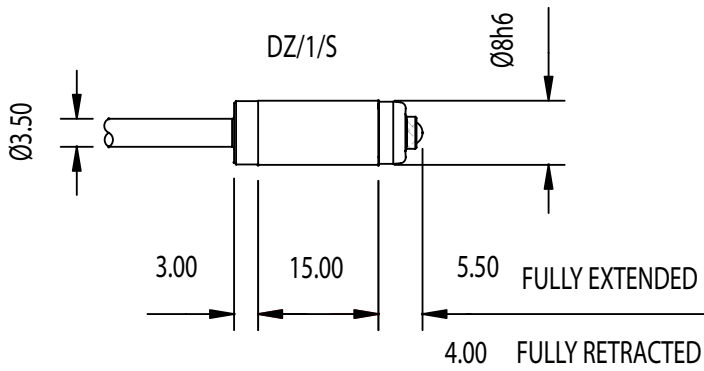

Figure showing general dimension and datum surfaces (please refer to the technical drawing for the complete set of dimensions)

Technical Specification

Product type	Digital	Digital
	DZ/1/S	DZ/2/S
Axial cable outlet: Standard Spring	DZ/1/S	DZ/2/S
Radial Cable Outlet: Standard Spring	DZR/1/S	DZR/2/S

Measurement

Measurement Range (mm)	1	2
Accuracy ⁽¹⁾ (% of reading)	< 0.1 %	< 0.1 %
Resolution	up to .01 µm User Selectable	
Repeatability ⁽²⁾ µm	0.15	0.15
Pre-travel (mm)	0.15	0.15
Post-travel (mm)	0.35	0.35
Pre-travel Adjustment range (mm)	N/A	N/A
Tip force: Standard ±20% (N) at mid position	0.70	0.70
Temperature Coefficient % FS/°C	0.01	0.01

Mechanical

Body Diameter (mm)	8h6	8h6
--------------------	-----	-----

Materials

Case:	Stainless Steel
Tip:	Tungsten Carbide
Gaiter ³ :	Viton®
Cable ⁴ :	PUR

Environmental (Probe Head Only)

Storage Temp (°C)	-40 to + 100
Operating Temp with gaiter (°C)	+ 5 to + 80
Operating Temp without gaiter (°C)	-10 to + 80
IP Rating	IP65

- (1) Accuracy definition
- (2) Obtained by step gauging: Repeatedly pushing the probe against the edge of the intended target prior to recording the measurement. This replicates the actual DZ operation in the field.
- (3) Viton is a trademark of DuPont Dow Elastomers
- (4) All probes are supplied with 2 m of PUR cable as standard. Other lengths and options such as nylon braided, metal braided and armoured are available on request.

Digital Probe interface Electronics	
Reading Rate:	Up to 3906 readings/second
Bandwidth:	Up to 460 Hz dependent on noise performance required
Output:	Serial communication -RS485 signal level (solartron Orbit Protocol)
Power:	5 ±0.25 VDC @ 0.06A (includes power for probe)
Storage Temp (°C)	-20 to +70
Operating Temp (°C)	0 to +60
IP Rating	IP43

If you have a specific requirement, please contact your local Solartron Metrology office.

Also Available at Solartron Metrology

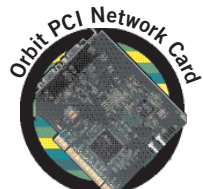
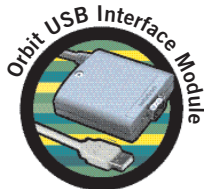
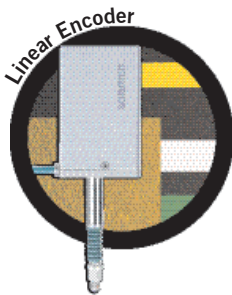
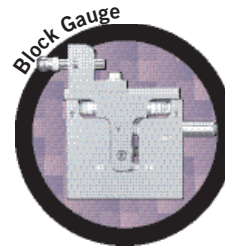
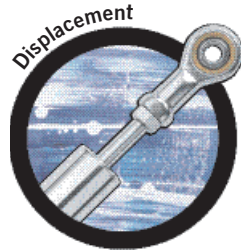
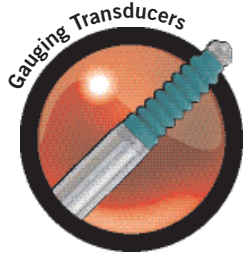

Solartron Metrology Offices

Addresses for Offices worldwide

United Kingdom - Head Office
Solartron Metrology
Steyning Way
Bognor Regis
West Sussex
PO22 9ST

Tel: +44 (0) 1243 833333
Fax: +44 (0) 1243 833332
sales.solartronmetrology@ametek.com

Germany
Ametek GmbH
Solartron Metrology Division
Rudolf-Diesel-Strasse 16
40670 Meerbusch

Tel: +49 (0) 2159 9136 500
Fax: +49 (0) 2159 9136 505
vertrieb.solartronmetrology@ametek.com

France
Solartron Metrology
Rond-point de l'Epine des Champs
Buroplus - Bat D
Elancourt, 78990

Tel: +33 (0)1 30 68 89 50
Fax: +33 (0)1 30 68 89 59
france.solartronmetrology@ametek.com

China - Shanghai
Solartron Metrology
Rm 912, Metro Tower
No 30 Tian Yao Qiao Road, Shanghai
200030

Tel: +86 21 6426 8111
Fax: +86 21 6426 7818
china.solartronmetrology@ametek.com

China - Beijing
Solartron Metrology
Room 2202, CITIC Building
#19, Jianguomenwai Dajie
Beijing
100004 P.R. China

Tel: +86 10 8526 2111
Fax: +86 10 8526 2141
china.solartronmetrology@ametek.com

China - Chengdu
Solartron Metrology
AMETEK ChengDu Rep Office
Room 2408, Zongfu Building
35 Zongfu Road
Chengdu, Sichun, 610016, China

Tel: +86 28 8675 8111
Fax: +86 28 8675 8141
china.solartronmetrology@ametek.com

Japan
Solartron Metrology
4-5-37 Kamiosaki
Shinagawa-Ku
Tokyo
141-0021

Tel: +81(0) 3 3494 5131
Fax: +81 (0) 3 3494 5134
japan.solartronmetrology@ametek.com

U.S.A
Solartron Metrology
915 N.New Hope Road
Suite C, Gastonia
NC 28054, USA

Tel: +1 800 873 5838
Fax: +1 704 868 8466
usasales.solartronmetrology@ametek.com

Agent and Distributor details available at www.solartronmetrology.com

AMETEK
ULTRA PRECISION TECHNOLOGIES

Registered in England No. 04220056, 2 New Star Road, Leicester, LE4 9JQ

Solartron pursues a policy of continuous development. Specifications in this document may therefore be changed without notice.