

Tensolite Precision Harness & Assembly

Tensolite

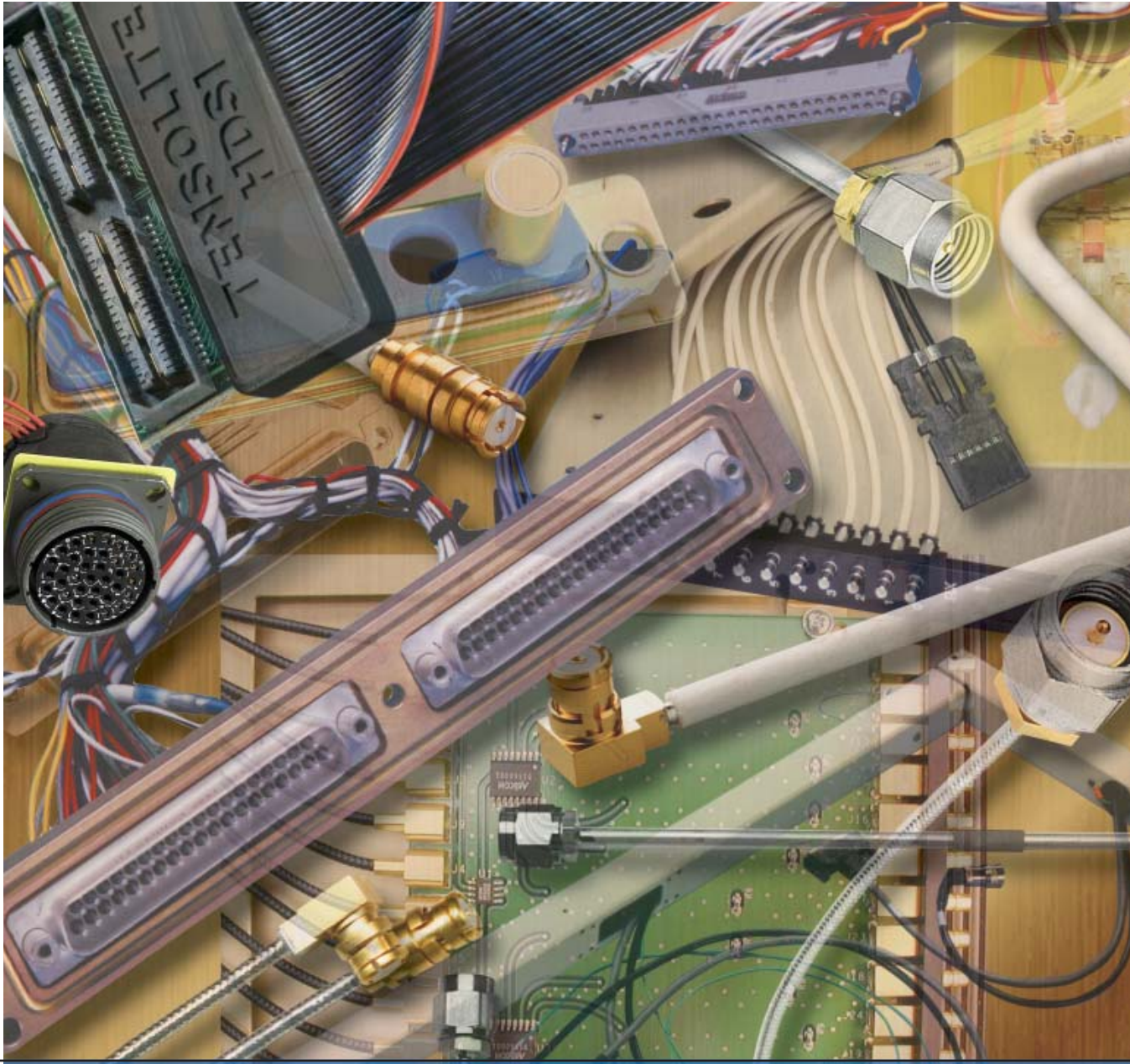

A **CARLISLE** Company



Contents

Custom Cable Assemblies:

- Complex Assemblies 3
- Cable Harnesses 4-5
- Electro-Mechanical 6
- Electrical Testing 7
- Probes 8
- Over-molding/Injection-molding 9
- Flat Ribbon and Flat Flex Assemblies 10
- RF/Microwave Flexible Cable Assemblies 11
- Semi-Rigid Cable Assemblies 12
- Delay Lines 13

RF/Microwave Standard Assemblies & Test Cables:

- Q-Flex and Q-Flex Plus Series 14-17
- Q-Flex Series Cable Specifications 18
- Semi-Flex, Semi-Flex Plus, Semi-Flex II . . 19-23
- Semi-Flex Series Cable Specifications 24
- Selection Guide 25
- Peltola RF Interconnect Systems 26-27
- Workhorse Test Cables Family 28-31
- Low Loss 301 Cable Assemblies 32

High Density Cable Assemblies:

- HM, HDM, and 100" Pitch System 33-34
- High Density Cable Styles 35
- HDSI and HDSI-DP Assemblies 36-37
- HDSI & HDSI-DP Part Numbering System . . 38
- HDSI Technical Data Test Results 39

Tensolite's Precision Harness and Assembly

Complex designs, multiple terminations and specialized connector configurations are challenges taken in stride when creating custom harnesses and assemblies. Since each product is unique, the engineering expertise of Tensolite's design team and our quick-turn prototype capabilities keep us at the forefront of interconnection technology.

Tensolite provides total solutions for your cable assembly, custom electro-mechanical assembly, and wire harness needs. Our products are utilized in a variety of markets including Aerospace, Test and Measurement, and Wireless Infrastructures.

Tensolite addresses critical issues such as impedance and skew for electrical performance, shielding to control EMI, strain relief and over-molding for mechanical integrity. Tensolite offers broad capabilities to meet these demands creating solutions for tomorrow's technology.



Complex Assemblies

With years of experience in building Complex Assemblies, Tensolite is continually improving our processes and productivity, enabling our customers to stay competitive in today's fast paced business world.

Combination D-Sub:

Offers a variety of applications for combining signal, high current, high voltage, and coaxial contacts.

- Variety of configurations
- Male and female
- Five different shell sizes
- Solder cup or crimp
- Yellow Zinc Chromate or Tin Plate
- Insulators are Glass Filled PBT UL94V-0
- Temperature range -55° to +105° C



Subminiature D-Subs:

Are used in industrial control systems, computers and telecommunications equipment of all kinds.

- Exceeds EMI/RFI FCC regulation 20780 Class A and B.
- Performs effectively with wide range of foil or braided shields.
- Comes in standard sizes, 9, 15, 25, 37, and 50 positions.
- Male and female connectors come in Yellow Zinc or Tin-Plating.



Subminiature Cylindrical Connectors MIL-DTL-38999

Assemblies offer the highest performance capabilities for both general duty and severe environment applications.

- EMI Shielding
- Vibration / Shock
- Quick Coupling
- Corrosion Resistance

Tensolite has a wide variety...

of other complex assemblies.

- SCSI cable assemblies
- Circular Din assemblies
- Aerospace cable assemblies:
 - ARINC Interconnects
 - Ethernet
 - IEEE 1394
 - Copper Fibre Channel Aerospace assemblies.
 - USB





Cable Harnesses

Cable harnesses come in all shapes and sizes, from 28 AWG hook-up wire to robust power carrying wire. There can be as many as several hundred contact points in a harness.

Products range from panel assemblies, power supplies, aftermarket automobile harnesses, to infrared camera harnesses. But whatever the size or complexity, we are always guided by our commitment to Quality and On-Time delivery.

- "Quick-Turn" Prototyping
- Engineering Design Capabilities
- Electrically tested on the build-board
- Combinations of single, multi-wire or coaxial cable
- UL Recognized/CSA Certified/ISO 9002 Approved

With short manufacturing lead-times, and daily deliveries, we can minimize your inventory investment.

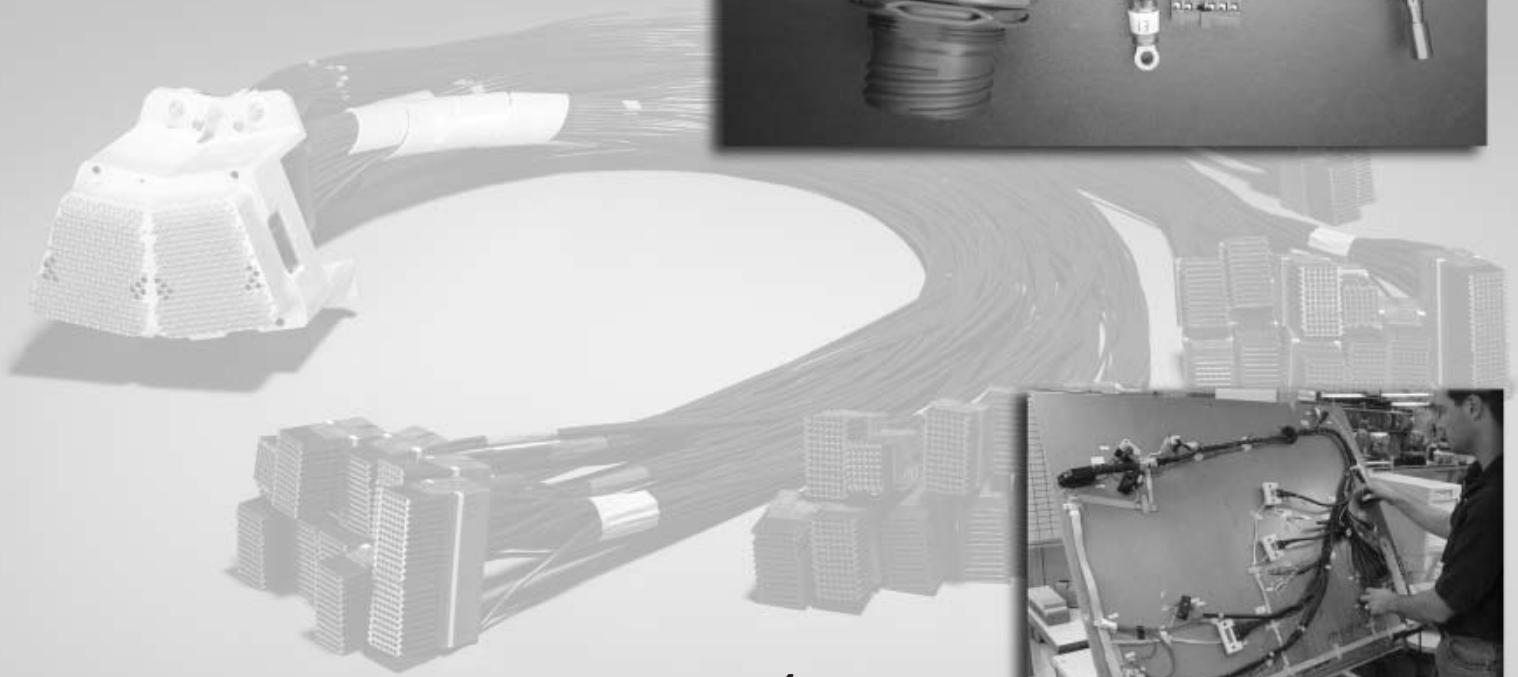
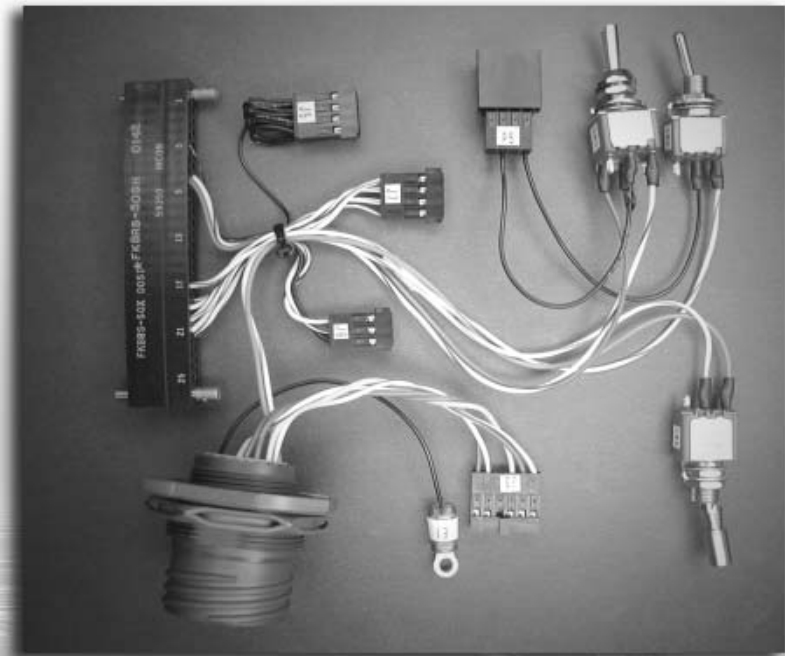
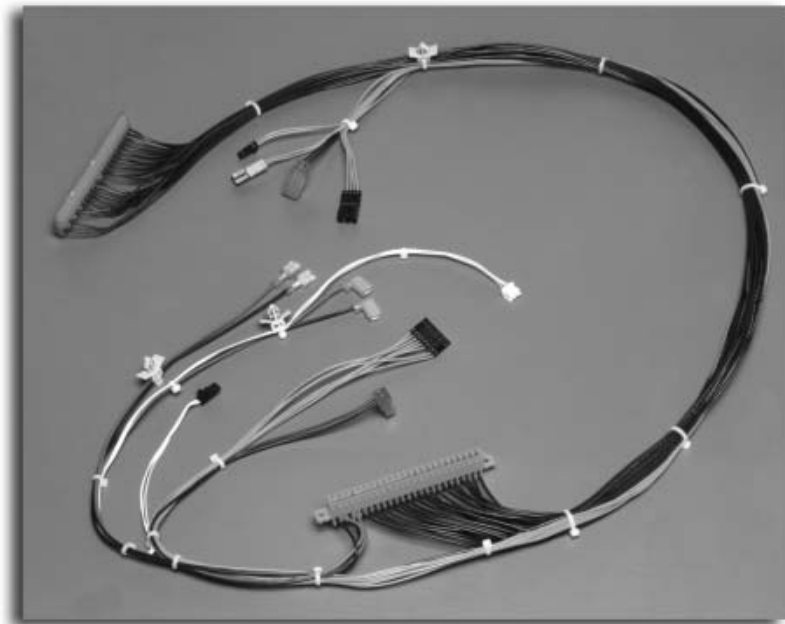

Cable Harnesses

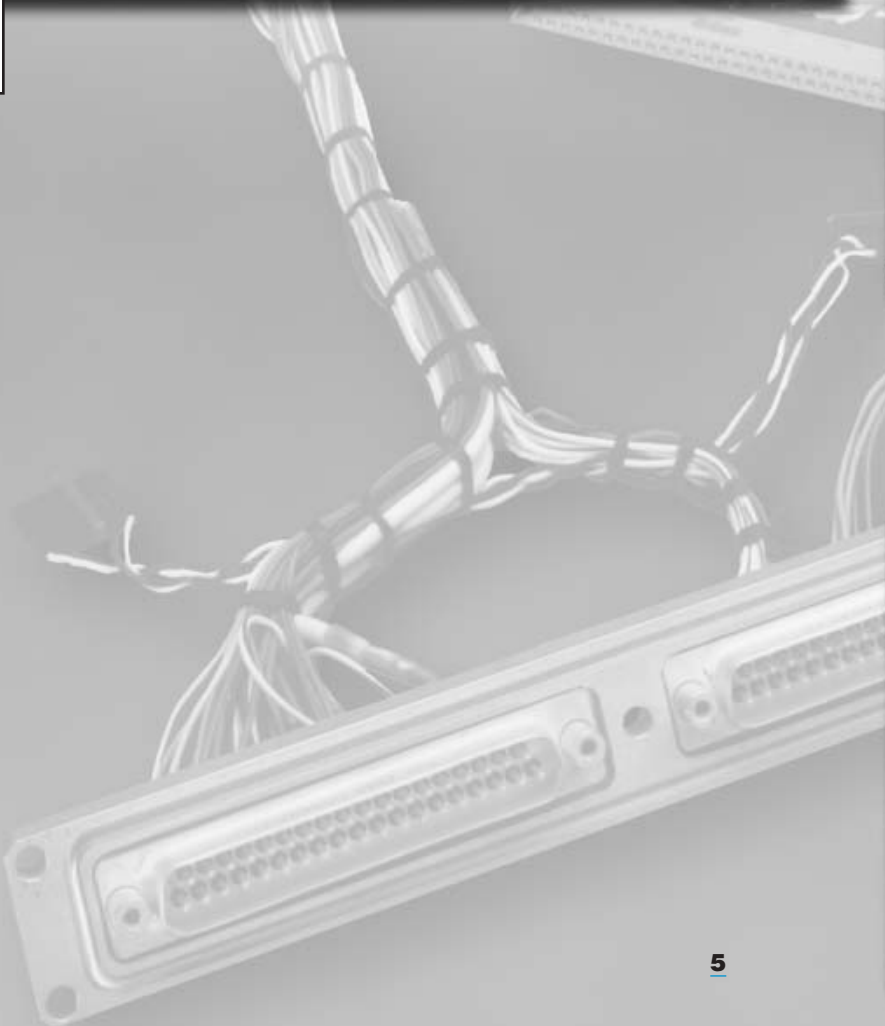
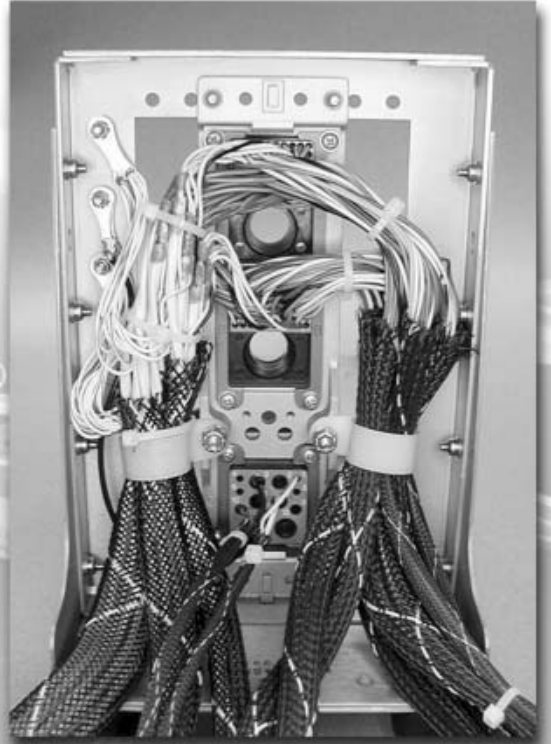

Electro-Mechanical

Tensolite, with decades of engineering and manufacturing experience, will procure all the subparts, build the custom cable to your specification, over-mold the connectors, assemble the module per your specifications and electrically test your product.

Many of our electro-mechanical products incorporate LED's, relays, breakers, toggle switches, RF filters, printed circuit boards, microcircuit connectors, and a variety of military circular connectors.

Capabilities:

- Over-molding
- Multistage Strip
- Automated cut, strip, crimp (Komax Gamma 333)
- Laser Cutting
- Induction Soldering
- Hot Bar Soldering
- Resistance Soldering
- Autosplice (soldering alternative)
- Ultrasonic Welding
- Video Inspection System
- Variety of Schleuniger Coaxial Cutting/Stripping equipment
- ESD environment

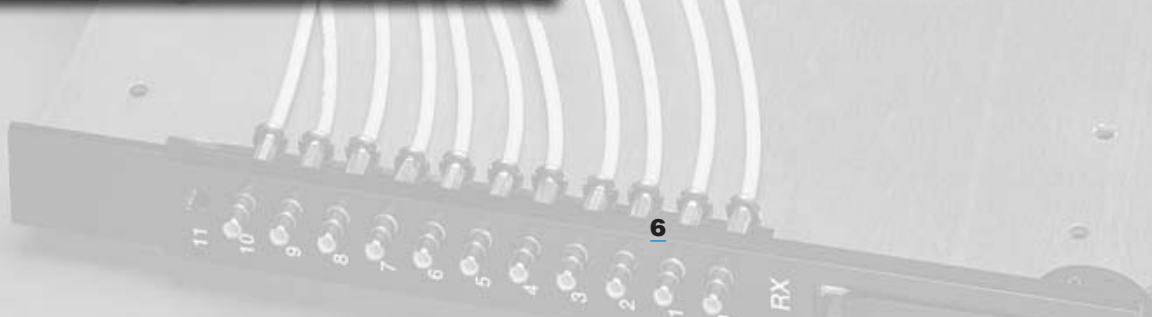
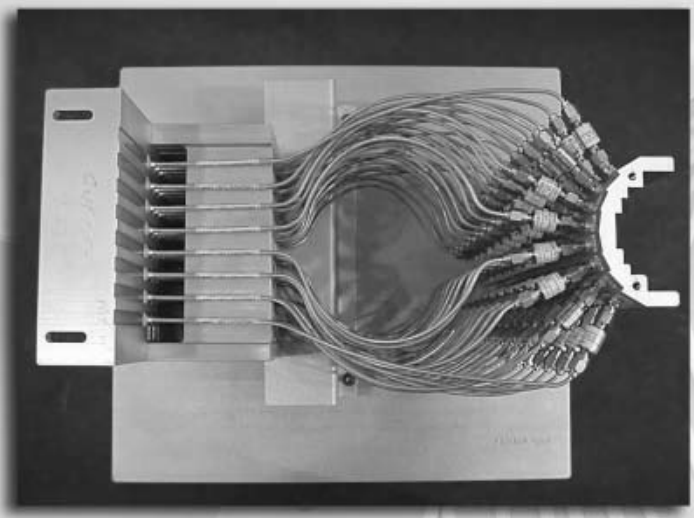
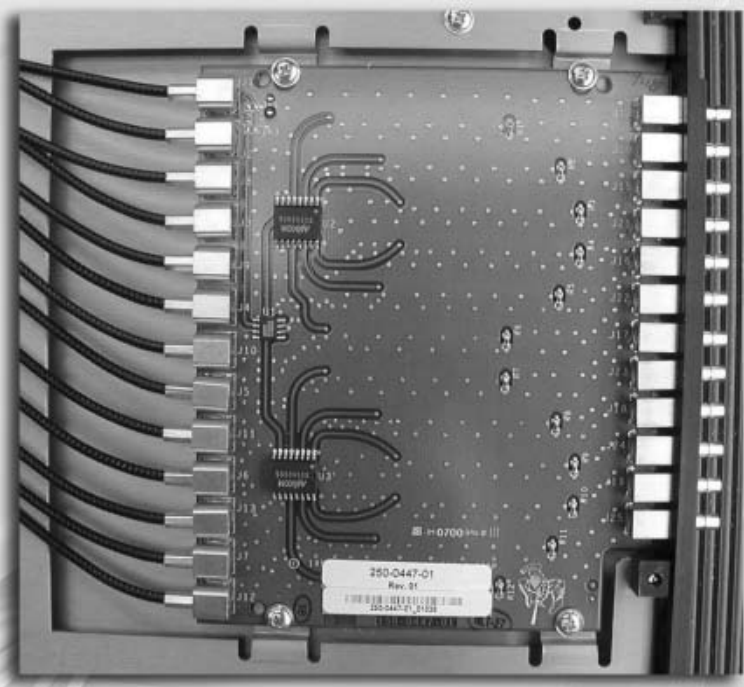
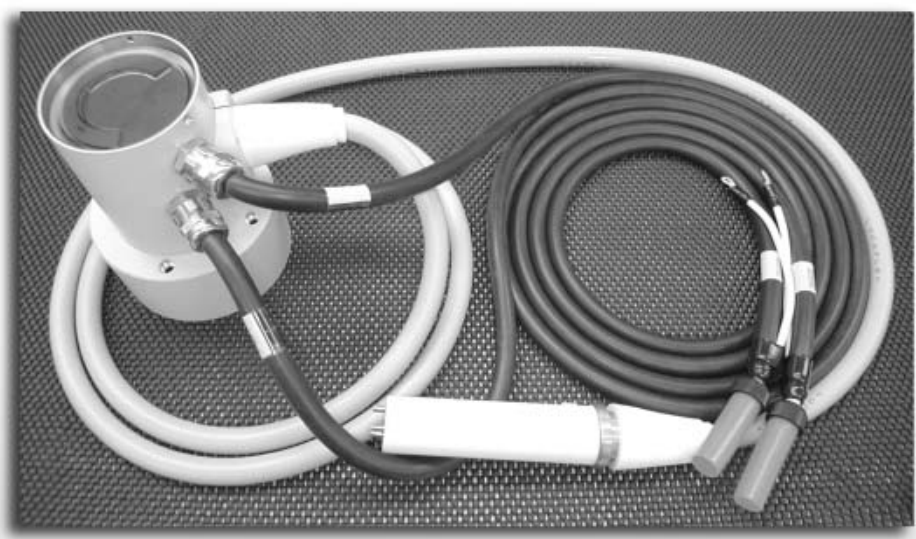



Electrical Testing

Tensolite builds quality into our products through our Lean Manufacturing processes. We test our products in-line as they are being built, assuring our customers that they are receiving high level, consistent quality everyday.

Our Quality Policy is simple and straight forward:

“Give our customers what they want, when they want it, 100% of the time.”

Tensolite’s philosophy is based on continuous improvement of our processes, contributing to the delivery of products and services to all of our customers.

General Purpose Electrical Testing:

Using Omni, Cirrus, and Checksum testing systems.

- Automatic self-learn of an assembly
- Loop-tests for intermittent failures
- Systems accommodate from 100 to 1,024 test points
- Insulation resistance testing up to 1,500VDC
- Test for opens and shorts
- Error logging in an exportable format
- AC Hipot, 1000V

RF/Microwave Testing:

Network analyzer capabilities to provide reflection and transmission measurements, and frequency range from 300 KHz to 65 GHz using our Vector, and Scalar Network Analyzers.

Reflection Measurements:

- VSWR
- Return Loss
- Reflection Coefficient

Impedance

- Transmission Measurements
- Insertion Loss
- Electrical Delay Phase Deviations
- Isolation (crosstalk)

TDR & TDT Measurements:

Time Domain Reflectometry and Time Domain Transmission measurements used for analyzing loss lines.

- Rise time degeneration
- Signal integrity analysis
- TDR characterization of cable & high-speed digital communications.
- True differential TDR measurements of dual coaxial cable and assemblies.

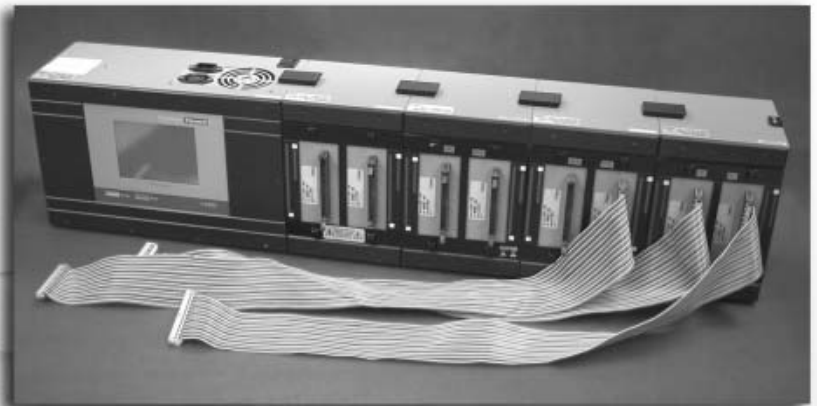



Probes

As the world of technology continues to increase, Tensolite offers broad capabilities to meet the demand for high-level probe products. By virtue of vertical integration, we can provide solutions for your cables, connectors, and assembly requirements.

Tensolite is a leading provider of custom probe assemblies. Whether they are active or passive probes, we can meet your specific application.

Typical Probe Types:

- SMT Probing Devices
- High Voltage Probes
- FET Probes
- Current Probes
- 50Ω Divider Probes
- Differential Probes
- Touch Screen Monitor Probes

Tensolite also strives to provide ultimate cost efficiencies through “quick-turn prototyping” and lean manufacturing techniques.

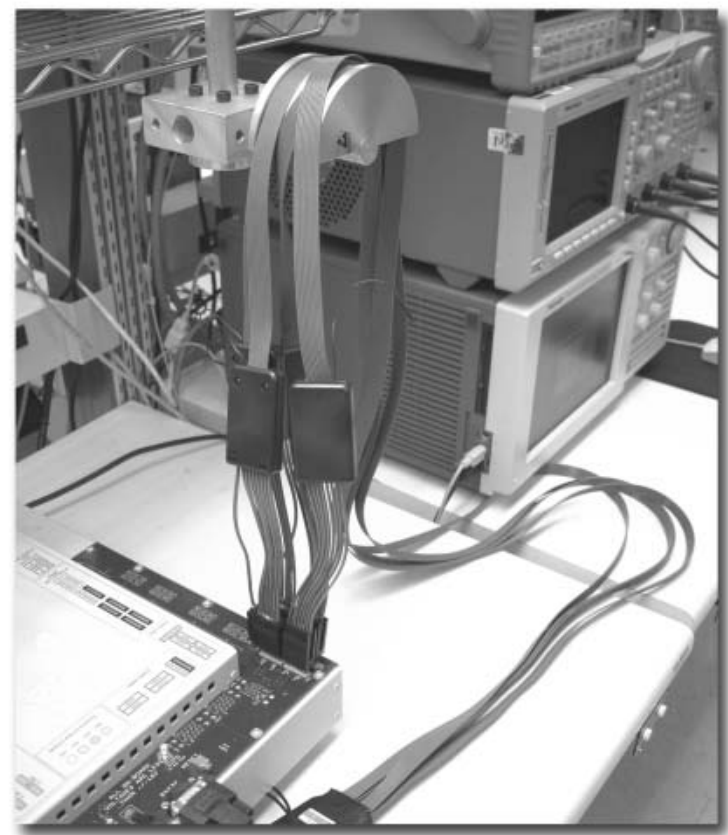



Overmolding/Injection Molding

Low-Pressure Molding

Our Mold-Man 8000 injection molding machine is designed for low-pressure molding with high performance polyamide resins.

This machine is intended for encapsulation of various electronic components and PCB's, molding of wiring harness components, grommets, connectors and plugs utilizing low-pressure molding.

Low-pressure molding machines melt the raw material completely prior to injection into the mold set. This enables molding at low pressures. The Macromelt polyamide resins are specifically formulated for this type of insert molding. The melted materials have relatively low viscosity and can be injected into the mold at 380°F to 450°F. The molding cycle is programmable from simple injections at pressures up to 500 psi to sophisticated injection profiles.

The mold temperature is controlled by the water-cooled upper and lower platens. This eliminates the need to drill cooling lines into the mold set and reduces mold design costs.

High-Pressure Molding

An overmolded strain-relief will increase the durability and life of your cable assembly. Tensolite's BOY 22DVH vertical injection molders can accommodate shot sizes up to 1.78 ounces and can process polymer and elastomer materials with temperature ranges up to 842°F. These 22-ton presses will accept molds 9.9" x 12".

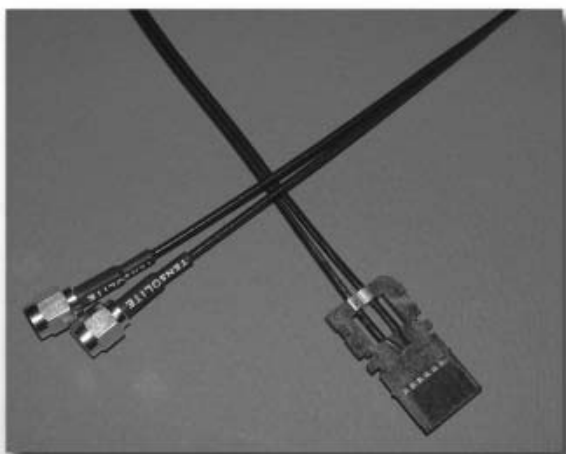



Flat Ribbon and Flat-Flex Assemblies

Tensolite offers a wide variety of Flat Ribbon (Flat Gray & Multi-Color) and Flat-Flex Film products. These products are versatile from the standpoint of time saving mass-terminations, one-to-one connector or as a complex harness allowing split-outs and special routing.

Multi-Conductor Flat Cable Assemblies

- Greatly facilitates identification
- Circuit tracing
- Breakouts for circuit routing
- Variety of IDC connectors available

Flat Gray Assemblies

- 2mm, .025", and .050" centerlines
- Semi-automated termination
- Can use as harness with staggered breakouts.
- Daisy-Chain assemblies, with notched cable and IDC connector configurations.

Through our Lean Manufacturing Processes, we can consistently handle any size order quantity our customers require.

Film Products (Flat-Flex)

- Available in .050" and .100" centerlines
- Voltage Rating 300 V
- Multi-million cycle flexibility
- Lighter weight, saves space over conventional harness methods
- Single and double row receptacles with or without latches.

The processes that are employed include flat cable cutting, crimping, separating conductors, mass termination and continuity testing.



RF/Microwave Flexible Cable Assemblies

Tensolite's RF/Microwave flexible cable assemblies are designed with the goal of cost effectiveness while continuing to provide the quality and workmanship through "quick turn prototyping" and Lean Manufacturing Processes.

The flexible assemblies are available in a variety of custom flexible microwave coax and RG MIL-C-17 rated coaxial cables ranging in small diameter such as RG-178 to large diameter RG-214.

Tensolite uses our own line of high performance connectors, and commercially available crimp style, non-captive contact connectors. All finishes and dimensions are IAW MIL-C 39012, and attachment strain reliefs are achieved through the use of MIL-I-23053 shrink tubing.

Applications:

- O.E.M.
- Aftermarket replacement
- Within test equipment
- Between test equipment hook-up
- Commercial/Telecommunications
- Radar/control systems

Features:

- Microwave frequency operation
- Highest quality commercial connectors
- Large selection
- Proven attachment methods
- On-time deliveries

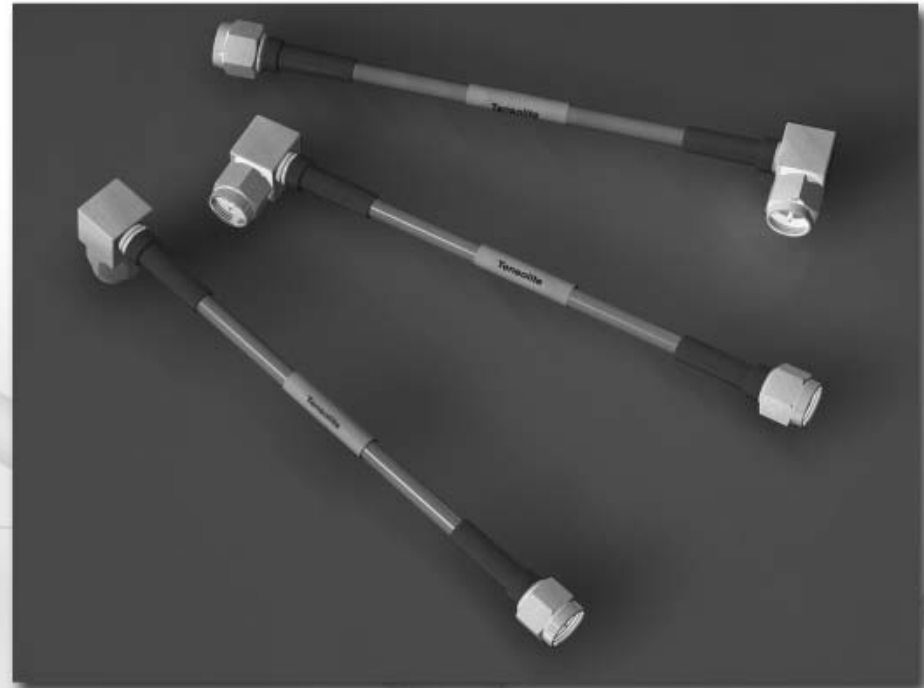

Semi-Rigid Cable Assemblies

Tensolite's semi-rigid cable assemblies are among the highest quality assemblies available today. We custom build these cables to meet your specifications.

Tensolite uses only the highest quality MIL-spec semi-rigid cable ranging from .034" to .250" in diameter, and a wide variety of commercial, QPL, and custom connectors including Tensolite's own line of high performance connectors ranging from SMP's, SSMP's, SMA's, smK's, BMA's, TNC's and Type N's.

All soldering is done in a MIL-STD-2000 environment by certified assemblers. We maintain a MIL-I-45208A inspection system with the calibration, sampling procedures and documentation to meet your most demanding requirements.

Applications:

- Military or commercial O.E.M.
- Test equipment
- High shielding environments
- Low cost RF transmission needs

Features:

- Computerized forming equipment
- In-house test capability through 65 GHz
- Tight phase matching capability
- Custom marking
- Rapid delivery

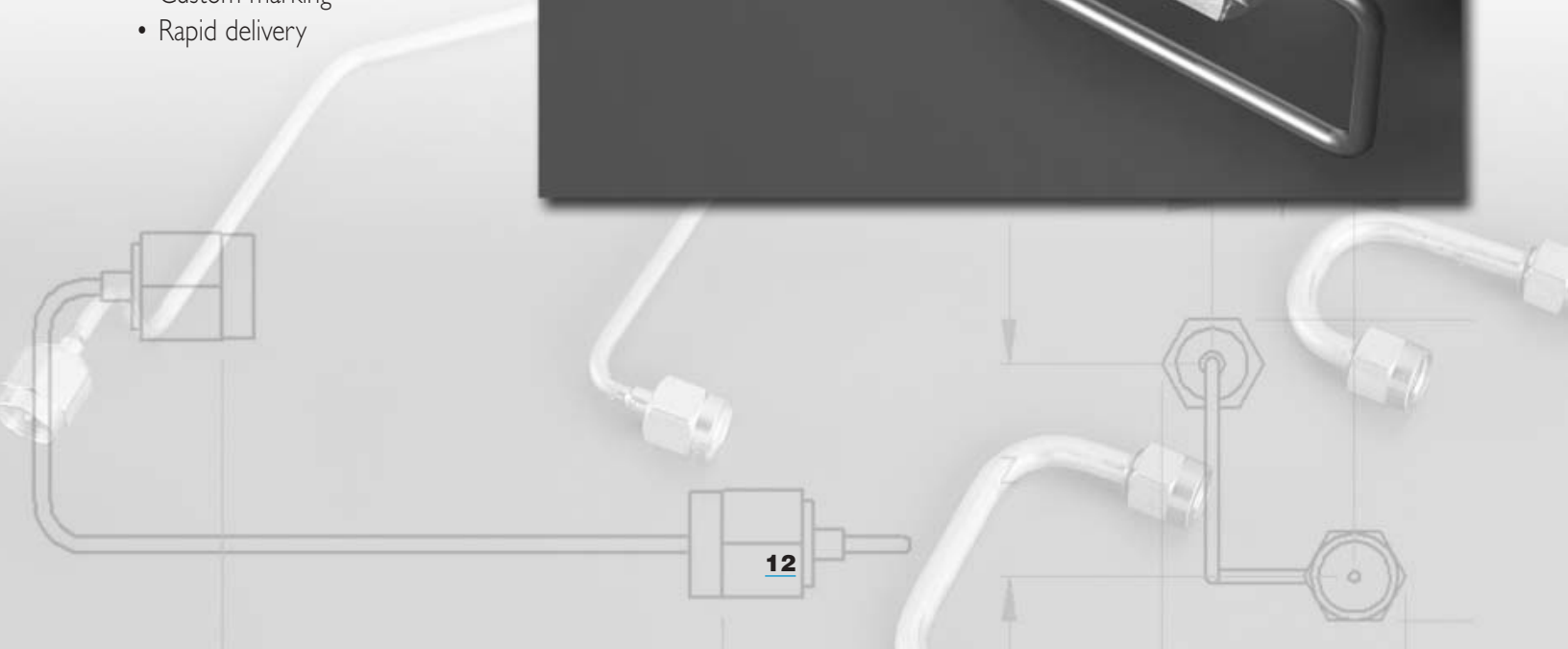
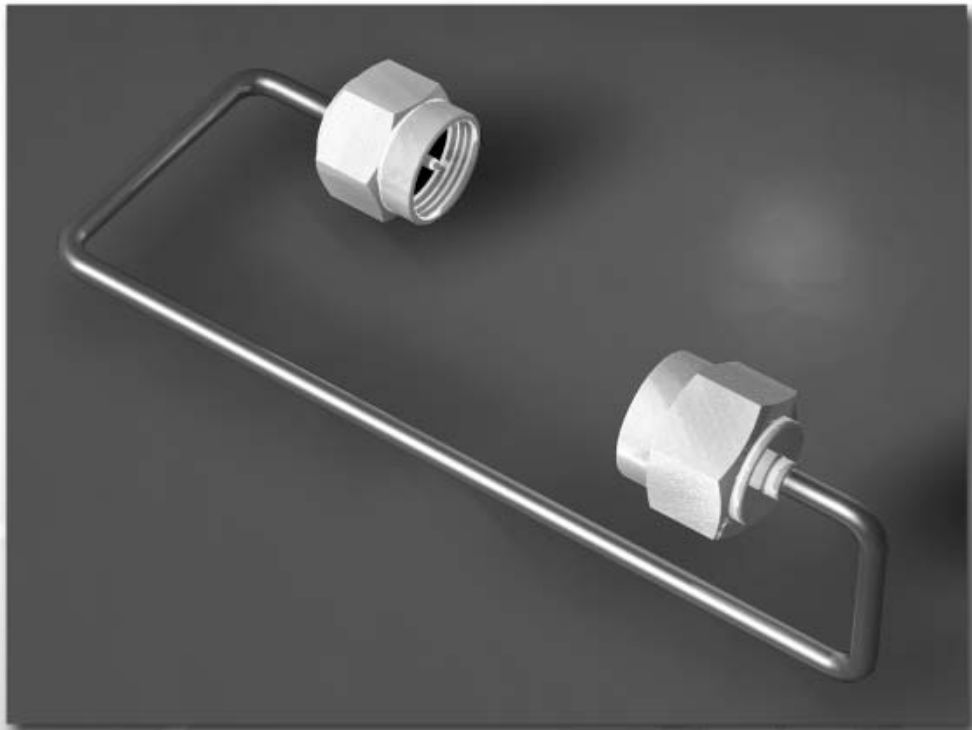



Delay Lines

Passive coax delay lines are an excellent means for providing short delays in RF and Microwave systems. Our engineers will work with you to configure a delay line solution that meets your specific electrical and packaging requirements.

Tensolite uses the highest quality semi-rigid and Semi-Flex® cable in sizes ranging from .047" to .250" in diameter as well as a variety of flexible coax cables. A wide variety of terminations are available including stripped ends for direct PCB termination.

Applications

- Land mobile radio
- Test equipment
- Cellular base stations

Features:

- Delay and skew tolerances to less than 15 ps
- Excellent phase stability
- Multiple delays in one package
- Low loss and VSWR

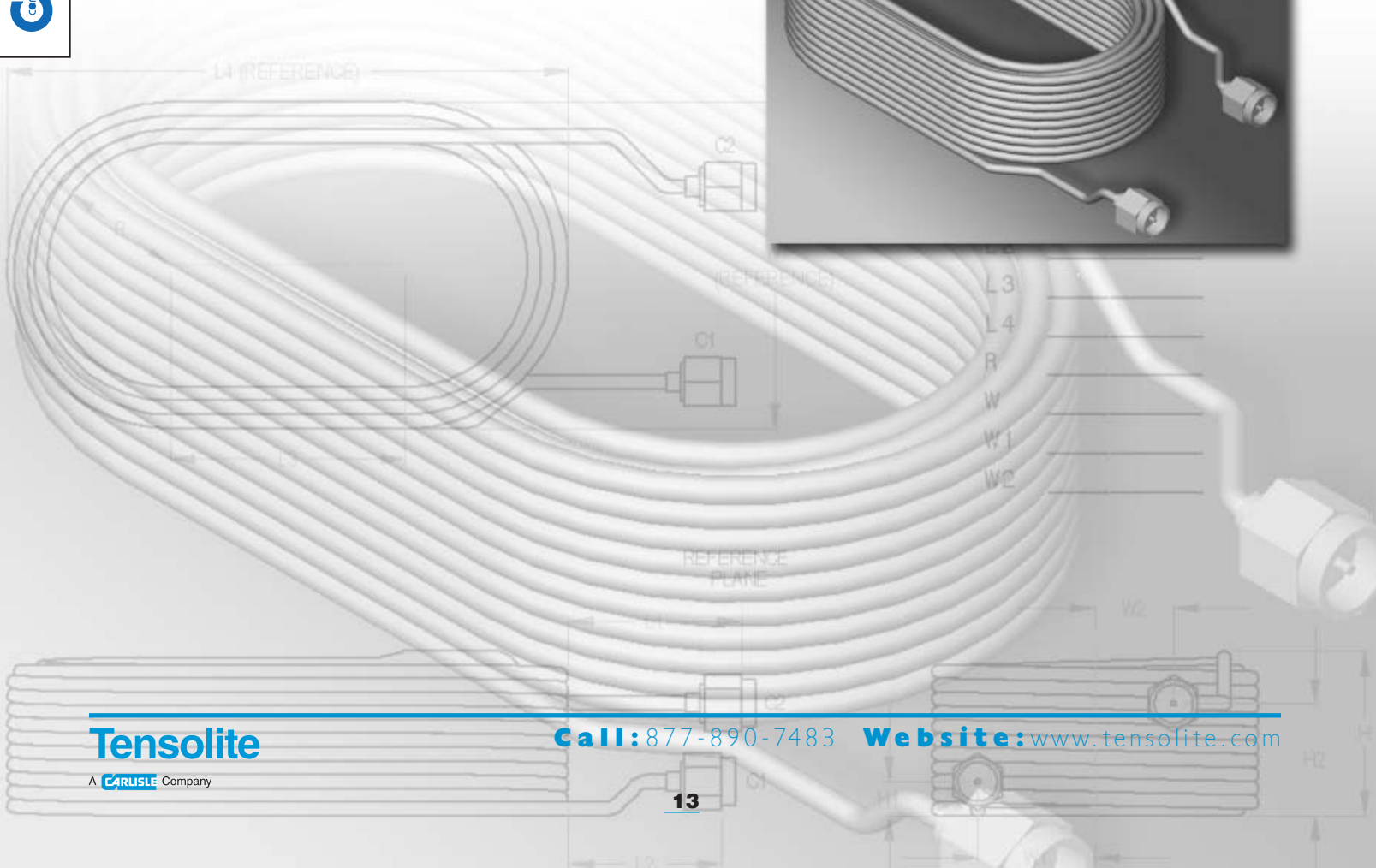
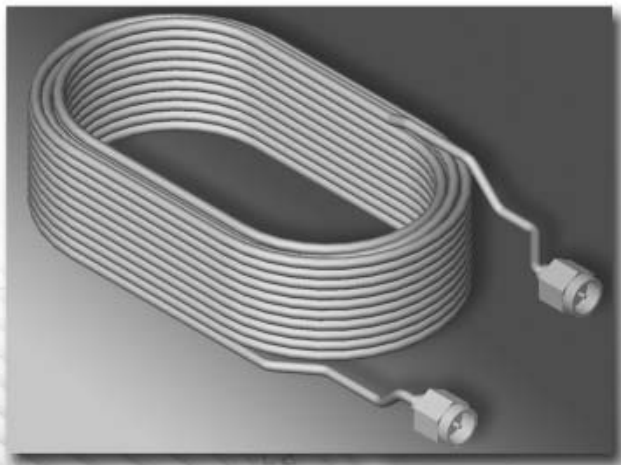
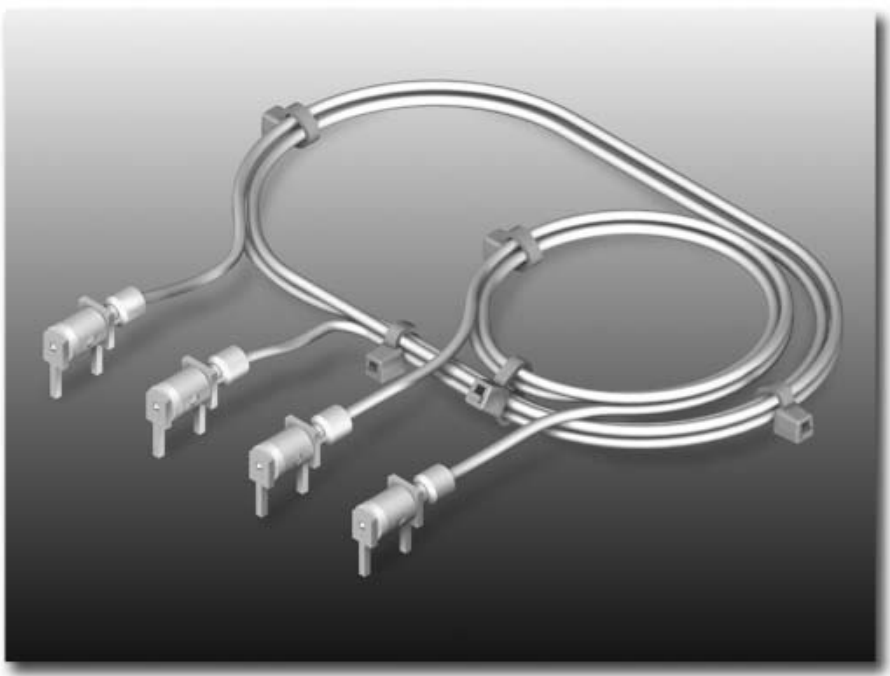

Tensolite

A CARLISLE Company

Call: 877-890-7483 Website: www.tensolite.com



RF/Microwave Standard Assemblies

Q-Flex® Series (to 40 GHz)

461/794/463/465 Assembly Codes

Q-Flex® assemblies, using Tensolite LLF coaxial cables, are a unique alternative to custom designed flexible coaxial cables.

Q-Flex® Plus Series

561/563/565 Assembly Codes

Q-Flex® Plus assemblies offer even greater flexibility with our polyurethane outer jacket for semi-rigid equivalent flexible coax cables.

Semi-Flex® Series

604/600/601/606 Assembly Codes

Semi-Flex® uses tin-filled braid outer conductor for easy flexing, with electrical performance comparable to semi-rigid, with no significant electrical degradation when formed.

Semi-Flex® Plus Series

620/621/650/651 Assembly Codes

Semi-Flex® Plus enhances Tensolite's Semi-Flex, by using a clear polyurethane jacket over the tin filled wire braid outer jacket. If your application calls for "High Temperature" (-50 to 200° C) Tensolite can apply our FEP jacket.

Semi-Flex® II Series

617/618 Assembly Codes (available in .086" & .141" diameters)

Semi-Flex® II is a thin walled, soft aluminum jacketed semi-rigid cable, which allows easier forming while retaining much of the electrical performance.

Low Cost, Low Loss

18GHz 301 Cable Assemblies

Tensolite's "301" cable ends the 3-way compromise users face when defining insertion loss, flexibility, and cost. Microporous PTFE design in .200" diameter is the low loss, low cost, flexible answer.

Workhorse®, Workhorse Plus®, Low Loss Workhorse®, and Armored Workhorse® Test Cable Families

Tensolite's Workhorse® Family is the result of years of assembly experience coupled with using our "504", "524", and "301" cables, which provide better flexibility and low loss performance. All Workhorse® assemblies utilize our rugged stainless steel connectors, and extremely durable attachment method.



Products listed on this page are in stock and guaranteed to meet specific electrical performance (18 GHz typical, 26.5 GHz optional), mating characteristics to MIL-STD-348, material, finish and configurations. Call for details.

Peltola Interconnect System

Tensolite's Peltola RF "Solderless" cable assembly is a proven low cost, electrically clean, reliable way to make RF cable connections between circuit boards or to back side panels. Available in 50 & 75Ω Impedance versions, and choices of through-hole vertical mount or SMT right angle receptacles.

Q-Flex® Series

Q-Flex® assemblies are a unique ALTERNATIVE to custom designed flexible coaxial cables. Traditionally custom specified, these cables are now available in various lengths and deliverable in 24 hours.

There is less than .05dB insertion loss with flexure, so your requirements for a stable cable are easily maintained.

Q-Flex® utilizes Tensolite's anti-torque SMA, SMP or a connector of your choice, thus extending the cable's useful life.

Assembly Cable Code	Bulk Cable P/N	OD
461	LLF-1087	.105"
794	HFF-1087	.105"
463	LLF-1141	.163"
465	LLF-1250	.270"

Flexible Alternatives to RG 405, 402 and 401 with improved attenuation

18 GHz SMA Male to SMA Male on 461 Q-Flex®

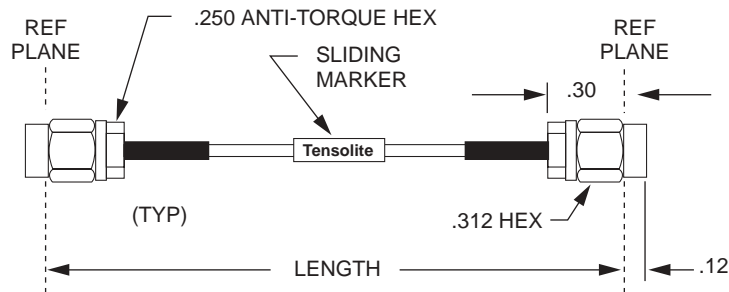

Tensolite Part Number	Length Inches	+ - Inches	Weight Ounces
1-3636-461-5204	4.00	0.25	0.3
1-3636-461-5205	5.00	0.25	0.3
1-3636-461-5206	6.00	0.25	0.3
1-3636-461-5208	8.00	0.25	0.3
1-3636-461-5212	12.00	0.25	0.3
1-3636-461-5218	18.00	0.25	0.5
1-3636-461-5224	24.00	0.25	0.7
1-3636-461-5236	36.00	0.36	0.9
1-3636-461-5248	48.00	0.48	1.2

1-3636-461-52XX
Your Length →

18 GHz SMA Male to SMA Male on 463 Q-Flex®

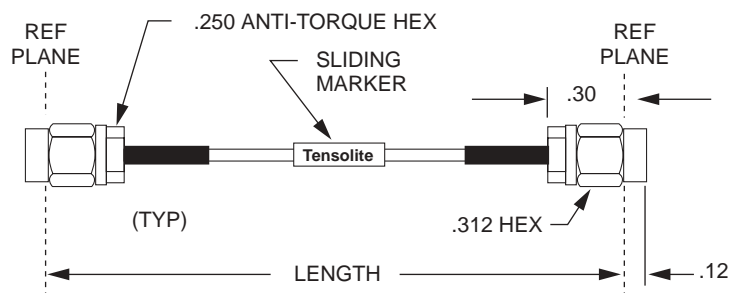

Tensolite Part Number	Length Inches	+ - Inches	Weight Ounces
1-3636-463-5204	4.00	0.25	0.5
1-3636-463-5205	5.00	0.25	0.5
1-3636-463-5206	6.00	0.25	0.6
1-3636-463-5208	8.00	0.25	0.7
1-3636-463-5212	12.00	0.25	0.9
1-3636-463-5218	18.00	0.25	1.2
1-3636-463-5224	24.00	0.25	1.6
1-3636-463-5236	36.00	0.36	2.2
1-3636-463-5248	48.00	0.48	2.9

1-3636-463-52XX
Your Length →

18 GHz SMA Male to SMA Male on 465 Q-Flex®

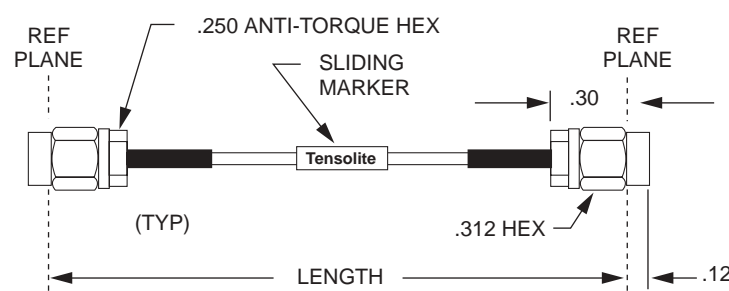

Tensolite Part Number	Length Inches	+ - Inches	Weight Ounces
1-3636-465-5204	4.00	0.25	0.7
1-3636-465-5205	5.00	0.25	0.8
1-3636-465-5206	6.00	0.25	0.9
1-3636-465-5208	8.00	0.25	1.1
1-3636-465-5212	12.00	0.25	1.6
1-3636-465-5218	18.00	0.25	2.2
1-3636-465-5224	24.00	0.25	2.9
1-3636-465-5236	36.00	0.36	4.2
1-3636-465-5248	48.00	0.48	5.5

1-3636-465-52XX
Your Length →

Q-Flex® Series

40 GHz smK Male to smK Male on 794 Q-Flex® Cable

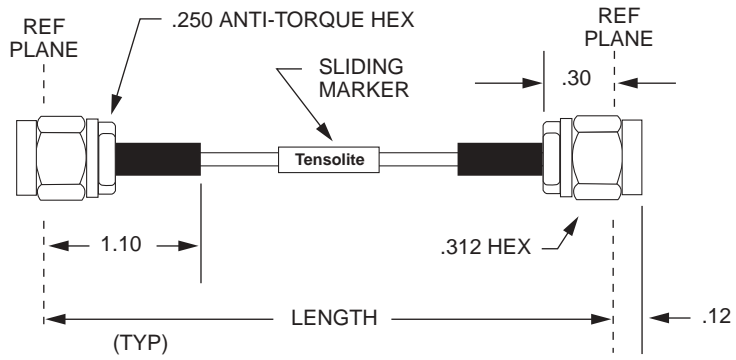

Tensolite Part Number	Length Inches	+ - Inches	Weight Ounces
1-K6K6-794-5304	4.00	0.25	0.3
1-K6K6-794-5305	5.00	0.25	0.3
1-K6K6-794-5306	6.00	0.25	0.3
1-K6K6-794-5308	8.00	0.25	0.3
1-K6K6-794-5312	12.00	0.25	0.4
1-K6K6-794-5318	18.00	0.25	0.5
1-K6K6-794-5324	24.00	0.25	0.7
1-K6K6-794-5336	36.00	0.36	0.9
1-K6K6-794-5348	48.00	0.48	1.2

1-K6K6-794-53XX
Your Length

40 GHz SMP Plug to SMP Plug on 794 Q-Flex® Cable

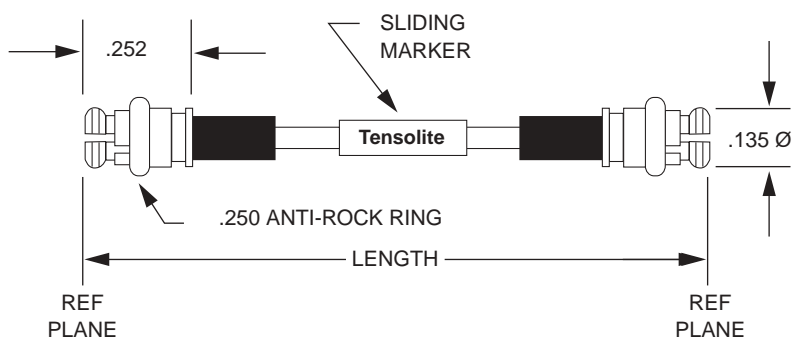

Tensolite Part Number	Length Inches	+ - Inches	Weight Ounces
1-G6G6-794-3304	4.00	0.25	0.3
1-G6G6-794-3305	5.00	0.25	0.3
1-G6G6-794-3306	6.00	0.25	0.3
1-G6G6-794-3308	8.00	0.25	0.3
1-G6G6-794-3312	12.00	0.25	0.4
1-G6G6-794-3318	18.00	0.25	0.5
1-G6G6-794-3324	24.00	0.25	0.7
1-G6G6-794-3336	36.00	0.36	0.9
1-G6G6-794-3348	48.00	0.48	1.2

1-G6G6-794-33XX
Your Length

26 GHz SMP Right Angle Plug to SMP Right Angle Plug on 794 Q-Flex® Cable

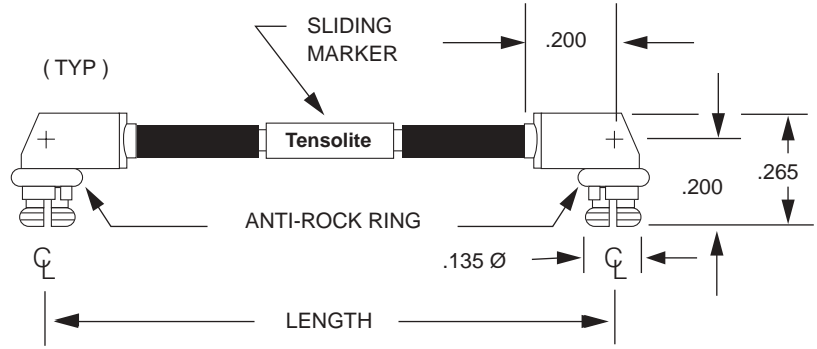

Tensolite Part Number	Length Inches	+ - Inches	Weight Ounces
1-G7G7-794-3304	4.00	0.25	0.3
1-G7G7-794-3305	5.00	0.25	0.3
1-G7G7-794-3306	6.00	0.25	0.3
1-G7G7-794-3308	8.00	0.25	0.3
1-G7G7-794-3312	12.00	0.25	0.4
1-G7G7-794-3318	18.00	0.25	0.5
1-G7G7-794-3324	24.00	0.25	0.7
1-G7G7-794-3336	36.00	0.36	0.9
1-G7G7-794-3348	48.00	0.48	1.2

1-G7G7-794-33XX
Your Length

Q-Flex® Plus Series

Q-Flex® Plus assemblies offer even greater flexibility for semi-rigid equivalent flexible coax cables. The coax is very flexible, that allows you to bend it in a tight radius without a lot of spring back. As an example, Q-Flex® Plus 561 bend force and spring back properties are only half the amount of standard flexible 405 cable. This makes it great for applications such as missile gimbals and test and measurement devices that are in tight locations.

Assembly Cable Code	Bulk Cable P/N	OD
561	LLFP-1087	.115"
563	LLFP-1141	.180"
565	LLFP-1250	.290"

Flexible Alternatives to RG 405, 402 and 401 with improved attenuation

18 GHz SMA Male to SMA Male on 561 Q-Flex® Plus Cable

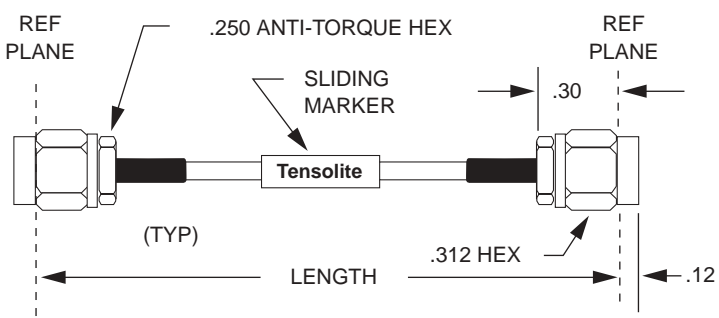

Tensolite Part Number	Length Inches	+ - Inches	Weight Ounces
1-3636-561-5204	4.00	0.25	0.3
1-3636-561-5205	5.00	0.25	0.3
1-3636-561-5206	6.00	0.25	0.3
1-3636-561-5208	8.00	0.25	0.3
1-3636-561-5212	12.00	0.25	0.4
1-3636-561-5218	18.00	0.25	0.5
1-3636-561-5224	24.00	0.25	0.7
1-3636-561-5236	36.00	0.36	0.9
1-3636-561-5248	48.00	0.48	1.2

1-3636-561-52XX
Your Length

18 GHz SMA Male to SMA Male on 563 Q-Flex®

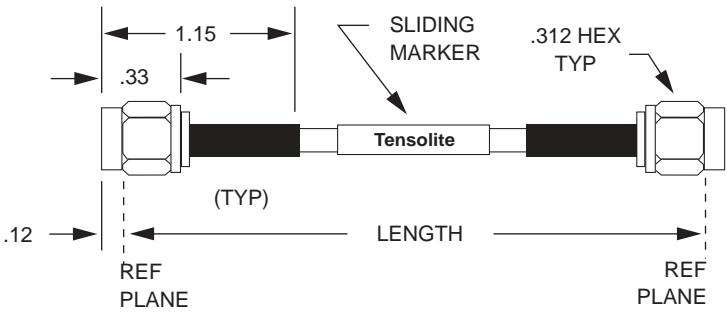

Tensolite Part Number	Length Inches	+ - Inches	Weight Ounces
1-3636-563-3204	4.00	0.3	0.5
1-3636-563-3205	5.00	0.3	0.5
1-3636-563-3206	6.00	0.25	0.6
1-3636-563-3207	7.00	0.25	0.6
1-3636-563-3208	8.00	0.25	0.7
1-3636-563-3210	10.00	0.25	0.8
1-3636-563-3212	12.00	0.25	0.9
1-3636-563-3218	18.00	0.25	1.2
1-3636-563-3224	24.00	0.25	1.6
1-3636-563-3236	36.00	0.36	2.2
1-3636-563-3248	48.00	0.48	2.9

1-3636-563-32XX
Your Length

SMA Male to SMA Male on 565 Q-Flex® Cable

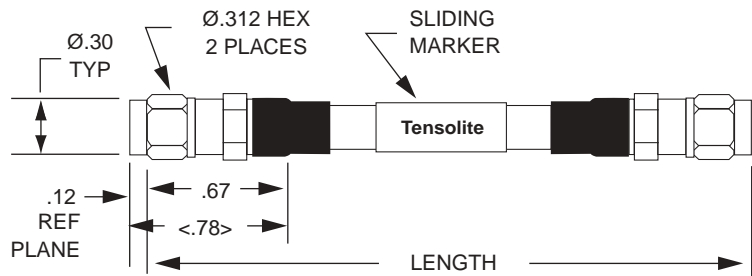

Tensolite Part Number	Length Inches	+ - Inches	Weight Ounces
1-3636-565-5105	5.00	0.05	0.8
1-3636-565-5106	6.00	0.05	0.9
1-3636-565-5107	7.00	0.10	1.0
1-3636-565-5108	8.00	0.10	1.2
1-3636-565-5112	12.00	0.10	1.6
1-3636-565-5118	18.00	0.15	2.4
1-3636-565-5124	24.00	0.20	3.1
1-3636-565-5137	37.00	0.20	4.7
1-3636-565-5148	48.00	0.25	6.0

1-3636-565-51XX
Your Length

Q-Flex® & Q-Flex® Plus Cable Specifications

Features:

- These 50 ohm cables provide low loss and stable, highly shielded signal handling.
- Insertion loss stability <.10 dB @ 2GHz/10 feet.
- Relative shielding effectiveness of <-90dB.
- Maximum operating frequency of 18 GHz.
- Q-Flex® Plus is highly flexible, doesn't spring back when flexed.
- Available in 100 / 250 / 500 foot spools.

Materials: Q-Flex®

- (A) Center conductor; Solid silver plated copper wire
- (B) Dielectric; Solid PTFE.
- (C) Interlayer; Silver plated helical wrapped copper.
- (D) Outer conductor; Silver plated copper wire braid.
- (E) Jacket; Blue FEP

Materials: Q-Flex® Plus

- (A) Center conductor; Stranded silver plated copper wire
- (B) Dielectric; Solid PTFE.
- (C) Interlayer; Silver plated helical wrapped copper.
- (D) Outer conductor; Silver plated copper wire braid.
- (E) Jacket; Clear Polyurethane

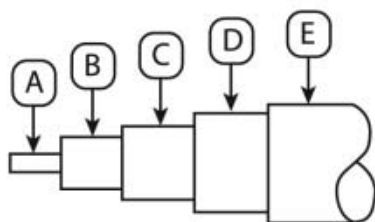

Part Number LLF-1087
461 Q-Flex®

Part Number LLFP-1087
561 Q-Flex® Plus

Mechanical		Electrical	
A: Dia.	0.020	Max pull (Lbs)	30
B: Dia.	0.065	Max Op Volts	1500
C: Dia.	0.073	Max Watts	102
D: Dia.	0.087	Cap. pF/Ft	29
E: Dia.	0.105	Velocity %	70
Temp Range (C)	-50 / 200	Loss dB/100/Ft	104
Weight Lbs./Ft	0.014	Delay nS/Ft	1.45

Mechanical		Electrical	
A: Dia.	0.021	Max pull (Lbs)	30
B: Dia.	0.063	Max Op Volts	1500
C: Dia.	0.071	Max Watts	8
D: Dia.	0.085	Cap. pF/Ft	29
E: Dia.	0.115	Velocity %	70
Temp Range (C)	-50 / 80	Loss dB/100/Ft	110.4
Weight Lbs./Ft	0.013	Delay nS/Ft	1.45

Part Number LLF-1141
463 Q-Flex®

Part Number LLFP-1141
563 Q-Flex® Plus

Mechanical		Electrical	
A: Dia.	0.036	Max pull (Lbs)	60
B: Dia.	0.117	Max Op Volts	1900
C: Dia.	0.128	Max Watts	168
D: Dia.	0.141	Cap. pF/Ft	29
E: Dia.	0.163	Velocity %	70
Temp Range (C)	-50 / 200	Loss dB/100/Ft	61.5
Weight Lbs./Ft	0.030	Delay nS/Ft	1.45

Mechanical		Electrical	
A: Dia.	0.038	Max pull (Lbs)	60
B: Dia.	0.116	Max Op Volts	1900
C: Dia.	0.126	Max Watts	11
D: Dia.	0.140	Cap. pF/Ft	29
E: Dia.	0.180	Velocity %	70
Temp Range (C)	-50 / 80	Loss dB/100/Ft	65.3
Weight Lbs./Ft	0.030	Delay nS/Ft	1.45

Part Number LLF-1250
465 Q-Flex®

Part Number LLFP-1250
565 Q-Flex® Plus

Mechanical		Electrical	
A: Dia.	0.064	Max pull (Lbs)	80
B: Dia.	0.209	Max Op Volts	3000
C: Dia.	0.217	Max Watts	225
D: Dia.	0.246	Cap. pF/Ft	29
E: Dia.	0.270	Velocity %	70
Temp Range (C)	-50 / 200	Loss dB/100/Ft	44.3
Weight Lbs./Ft	0.088	Delay nS/Ft	1.45

Mechanical		Electrical	
A: Dia.	0.068	Max pull (Lbs)	80
B: Dia.	0.211	Max Op Volts	3000
C: Dia.	0.224	Max Watts	19
D: Dia.	0.252	Cap. pF/Ft	29
E: Dia.	0.290	Velocity %	70
Temp Range (C)	-50 / 80	Loss dB/100/Ft	47.5
Weight Lbs./Ft	0.086	Delay nS/Ft	1.45

Semi-Flex® Series

SEMI-FLEX® is a unique ALTERNATIVE to the use of semi-rigid coax. A tin-filled wire braid outer conductor allows easy flexing and re-bending by hand. A solid copper secondary outer conductor and semi-rigid style core ensure electrical performance comparable to semi-rigid.

No significant electrical degradation occurs when SEMI-FLEX® is formed! The cable retains its shape, making installations simple.

Assembly Cable Code	Bulk Cable P/N	OD
604	7-1114-604-18	.047"
600	7-1114-600-18	.086"
601	7-1114-601-18	.141"
606	7-1114-606-18	.250"

18 GHz SMA Male to SMA Male on 604 Semi-Flex® Cable

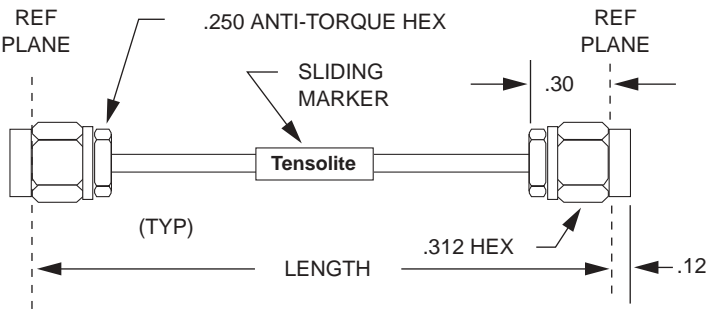

Tensolite Part Number	Length Inches	+ - Inches	Weight Ounces
1-3636-604-5206	6.00	0.10	0.2
1-3636-604-5209	9.00	0.10	0.2
1-3636-604-5212	12.00	0.15	0.3
1-3636-604-5218	18.00	0.15	0.3
1-3636-604-5224	24.00	0.15	0.3
1-3636-604-5236	36.00	0.20	0.4
1-3636-604-5248	48.00	0.20	0.4
1-3636-604-5260	60.00	0.20	0.5
1-3636-604-5272	72.00	0.20	0.5

1-3636-604-52XX
Your Length

18 GHz SMA Male to SMA Male on 600 Semi-Flex® Cable

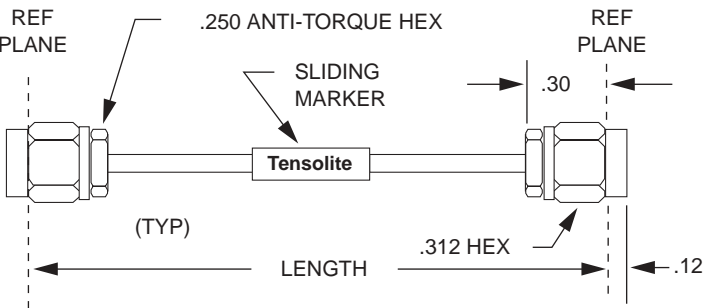

Tensolite Part Number	Length Inches	+ - Inches	Weight Ounces
1-3636-600-5204	4.00	0.05	0.2
1-3636-600-5205	5.00	0.10	0.3
1-3636-600-5206	6.00	0.10	0.3
1-3636-600-5208	8.00	0.10	0.3
1-3636-600-5212	12.00	0.15	0.4
1-3636-600-5218	18.00	0.15	0.5
1-3636-600-5224	24.00	0.15	0.6
1-3636-600-5236	36.00	0.20	0.8
1-3636-600-5248	48.00	0.25	1.0

1-3636-600-52XX
Your Length

18 GHz SMA Male to SMA Male on 601 Semi-Flex® Cable

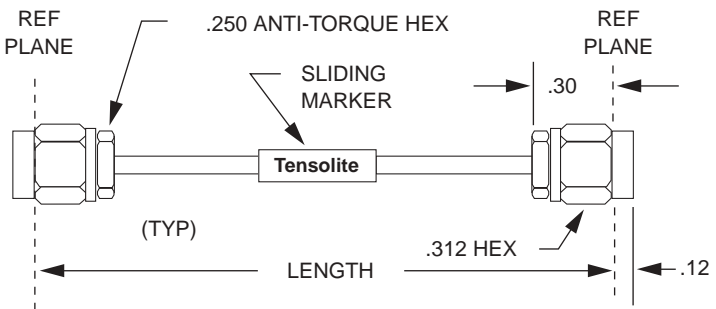

Tensolite Part Number	Length Inches	+ - Inches	Weight Ounces
1-3636-601-5204	4.00	0.05	0.3
1-3636-601-5205	5.00	0.10	0.3
1-3636-601-5206	6.00	0.10	0.4
1-3636-601-5208	8.00	0.10	0.4
1-3636-601-5212	12.00	0.15	0.6
1-3636-601-5218	18.00	0.15	0.8
1-3636-601-5224	24.00	0.15	0.9
1-3636-601-5236	36.00	0.20	1.3
1-3636-601-5248	48.00	0.25	1.7

1-3636-601-52XX
Your Length

Semi-Flex® Series

18 GHz SMA Male Right Angle to Right Angle on 600 Semi-Flex® Cable

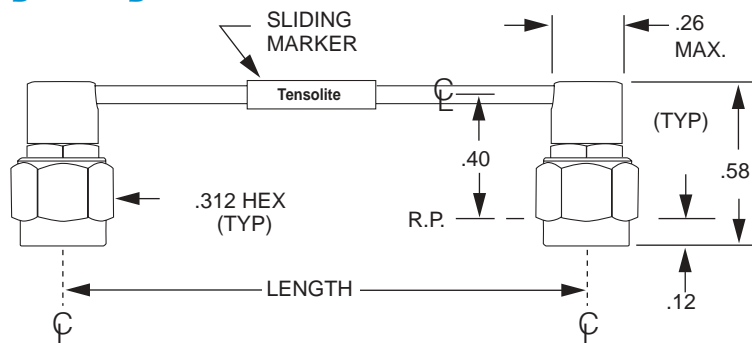

Tensolite Part Number	Length Inches	+ - Inches	Weight Ounces
1-3737-600-3204	4.00	0.05	0.3
1-3737-600-3205	5.00	0.05	0.4
1-3737-600-3206	6.00	0.05	0.4
1-3737-600-3208	8.00	0.10	0.4
1-3737-600-3212	12.00	0.10	0.5
1-3737-600-3218	18.00	0.15	0.5
1-3737-600-3224	24.00	0.15	0.6
1-3737-600-3236	36.00	0.15	0.8
1-3737-600-3248	48.00	0.20	1.0

1-3737-600-32XX

Your Length

18 GHz SMA Male to SMA Male Right Angle on 600 Semi-Flex®

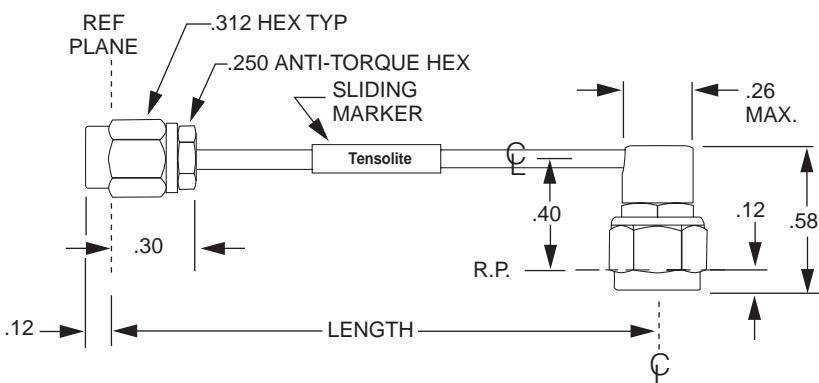

Tensolite Part Number	Length Inches	+ - Inches	Weight Ounces
1-3637-600-5204	4.00	0.05	0.2
1-3637-600-5205	5.00	0.10	0.3
1-3637-600-5206	6.00	0.10	0.3
1-3637-600-5208	8.00	0.10	0.3
1-3637-600-5212	12.00	0.15	0.4
1-3637-600-5218	18.00	0.15	0.4
1-3637-600-5224	24.00	0.15	0.5
1-3637-600-5236	36.00	0.20	0.7
1-3637-600-5248	48.00	0.25	0.9

1-3637-600-52XX

Your Length

6 GHz SMA Male to MCX Male Right Angle on 600 Semi-Flex®

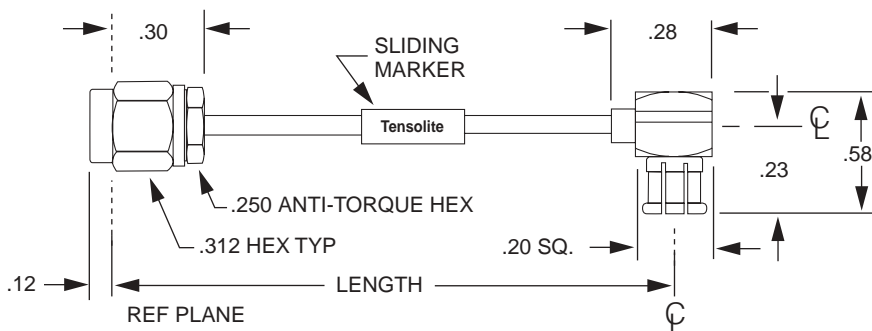

Tensolite Part Number	Length Inches	+ - Inches	Weight Ounces
1-36M7-600-5204	4.00	0.25	0.3
1-3M7-600-5205	5.00	0.25	0.3
1-36M7-600-5206	6.00	0.25	0.3
1-36M7-600-5208	8.00	0.25	0.3
1-36M7-600-5212	12.00	0.25	0.4
1-36M7-600-5218	18.00	0.25	0.5
1-36M7-600-5224	24.00	0.24	0.6
1-36M7-600-5236	36.00	0.36	0.8
1-36M7-600-5248	48.00	0.48	0.9

1-36M7-600-52XX

Your Length



Semi-Flex® Series

40 GHz SMP Plug to SMP Plug on 600 Semi-Flex® Cable

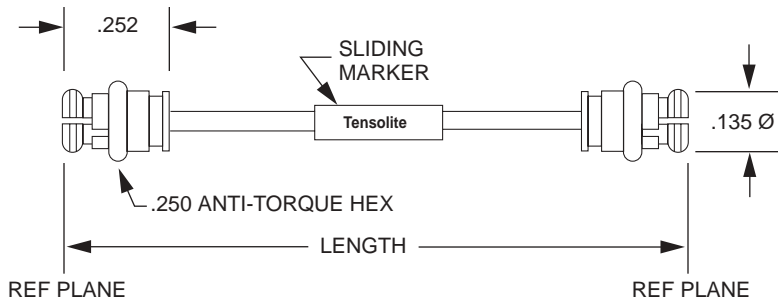

Tensolite Part Number	Length Inches	+ - Inches	Weight Ounces
1-G6G6-600-3404	4.00	0.05	0.2
1-G6G6-600-3405	5.00	0.10	0.3
1-G6G6-600-3406	6.00	0.10	0.3
1-G6G6-600-3408	8.00	0.10	0.3
1-G6G6-600-3412	12.00	0.15	0.4
1-G6G6-600-3418	18.00	0.15	0.5
1-G6G6-600-3424	24.00	0.15	0.6
1-G6G6-600-3436	36.00	0.20	0.8
1-G6G6-600-3448	48.00	0.25	1.0

1-G6G6-600-34XX
Your Length

26.5 GHz SMP Right Angle Plug to SMP Right Angle Plug on 600 Semi-Flex® Cable

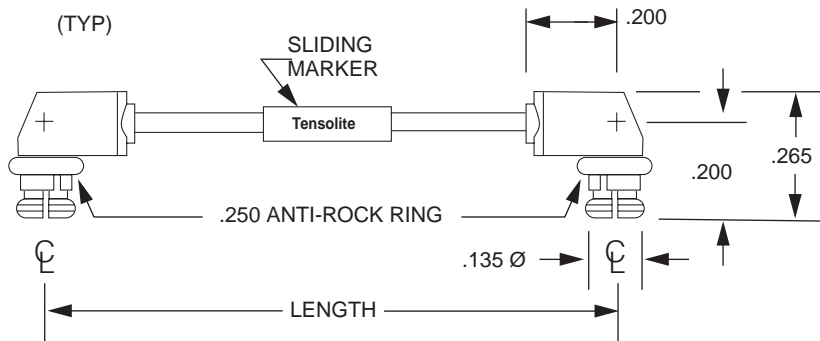

Tensolite Part Number	Length Inches	+ - Inches	Weight Ounces
1-G7G7-600-3304	4.00	0.05	0.2
1-G7G7-600-3305	5.00	0.10	0.3
1-G7G7-600-3306	6.00	0.10	0.3
1-G7G7-600-3308	8.00	0.10	0.3
1-G7G7-600-3312	12.00	0.15	0.4
1-G7G7-600-3318	18.00	0.15	0.5
1-G7G7-600-3324	24.00	0.15	0.6
1-G7G7-600-3336	36.00	0.20	0.8
1-G7G7-600-3348	48.00	0.25	1.0

1-G7G7-600-33XX
Your Length

18 GHz Type N Male to Type N Male on 606 Semi-Flex® Cable

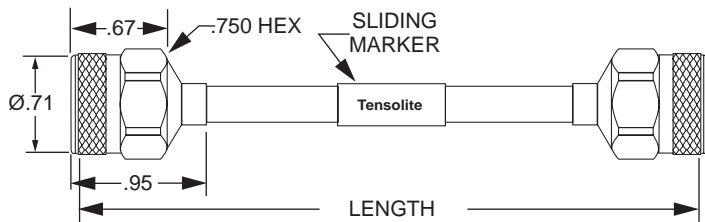

Tensolite Part Number	Length Inches	+ - Inches	Weight Ounces
1-1818-606-3204	4.00	0.10	2.56
1-1818-606-3205	5.00	0.10	2.68
1-1818-606-3206	6.00	0.10	2.80
1-1818-606-3208	8.00	0.10	3.05
1-1818-606-3212	12.00	0.10	3.53
1-1818-606-3218	18.00	0.15	4.26
1-1818-606-3224	24.00	0.15	4.99
1-1818-606-3236	36.00	0.15	6.44
1-1818-606-3248	48.00	0.20	7.90

1-1818-606-32XX
Your Length

Semi-Flex® Plus Series

Semi-Flex® Plus allows the user to have the advantages of a hand formable cable and a flexible cable all in one. Semi-Flex® Plus enhances Tensolite's Semi-Flex® by using a clear polyurethane jacket over a tin-filled wire braid outer conductor. A solid secondary outer conductor and semi-rigid style core ensure electrical performance comparable to semi-rigid. If your application calls for High Temperature, use our Semi-Flex® Plus "High Temperature" 650 or 651 Series (-50 to 200° C) by adding our FEP jacket.

Assembly Cable Code	OD
620	.112"
621	.180"
650	.100"
651	.151"

18 GHz SMA Male to SMA Male on 620 Jacketed Semi-Flex® Cable

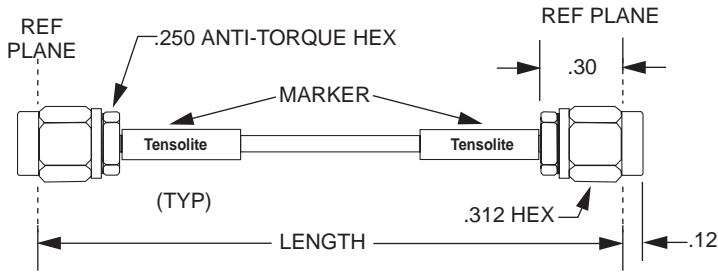

Tensolite Part Number	Length Inches	+ - Inches	Weight Ounces
1-3636-620-5204	4.00	0.05	0.3
1-3636-620-5205	5.00	0.05	0.3
1-3636-620-5206	6.00	0.10	0.3
1-3636-620-5208	8.00	0.10	0.3
1-3636-620-5212	12.00	0.15	0.4
1-3636-620-5218	18.00	0.15	0.5
1-3636-620-5224	24.00	0.15	0.7
1-3636-620-5236	36.00	0.15	0.9
1-3636-620-5248	48.00	0.20	1.1

1-3636-620-52XX
Your Length

18 GHz SMA Male Right Angles on 620 Semi-Flex®

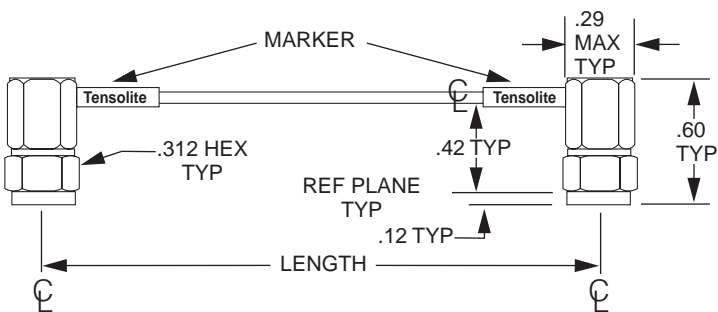

Tensolite Part Number	Length Inches	+ - Inches	Weight Ounces
1-3737-620-3204	4.00	0.05	0.4
1-3737-620-3205	5.00	0.05	0.4
1-3737-620-3206	6.00	0.10	0.4
1-3737-620-3208	8.00	0.10	0.4
1-3737-620-3212	12.00	0.15	0.5
1-3737-620-3218	18.00	0.15	0.6
1-3737-620-3224	24.00	0.15	0.8
1-3737-620-3236	36.00	0.15	1.0
1-3737-620-3248	48.00	0.20	1.2

1-3737-620-32XX
Your Length

18 GHz type N Male to Type N Male on 621 Jacketed Semi-Flex® Cable

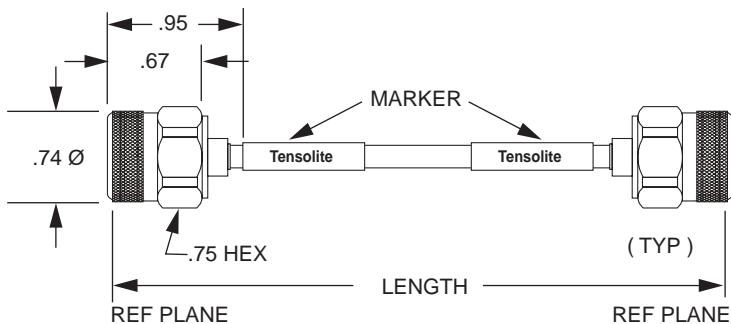

Tensolite Part Number	Length Inches	+ - Inches	Weight Ounces
1-1818-621-3204	4.00	0.05	2.2
1-1818-621-3205	5.00	0.05	2.2
1-1818-621-3206	6.00	0.05	2.3
1-1818-621-3208	8.00	0.10	2.4
1-1818-621-3212	12.00	0.10	2.5
1-1818-621-3218	18.00	0.15	2.7
1-1818-621-3224	24.00	0.15	2.9
1-1818-621-3236	36.00	0.15	3.3
1-1818-621-3248	48.00	0.20	3.7

1-1818-621-32XX
Your Length



Semi-Flex® II Series

Semi-Flex® II is a thin walled, soft aluminum jacketed semi-rigid cable. The more pliable outer conductor allows easier forming than copper jacketed cable while retaining much of the same electrical performance.

Semi-Flex® II, along with original, high performance Semi-Flex®, rounds out the designer's options for alternatives to traditional semi-rigid cable assemblies.

Assembly Cable Code	OD
617	.086"
618	.141"

18 GHz SMA Male to SMA Male on 617 Semi-Flex® II Cable

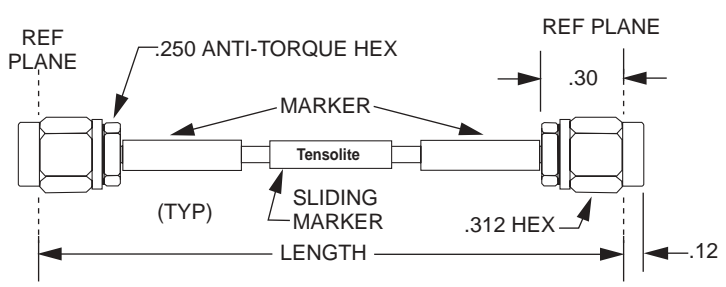

Tensolite Part Number	Length Inches	+ - Inches	Weight Ounces
1-3636-617-5204	4.00	0.05	0.2
1-3636-617-5205	5.00	0.10	0.2
1-3636-617-5206	6.00	0.10	0.2
1-3636-617-5208	8.00	0.10	0.3
1-3636-617-5212	12.00	0.15	0.3
1-3636-617-5218	18.00	0.15	0.4
1-3636-617-5224	24.00	0.15	0.4
1-3636-617-5236	36.00	0.20	0.6
1-3636-617-5248	48.00	0.25	0.7

1-3636-617-52XX
Your Length →

18 GHz SMA Male to SMA Male on 618 Semi-Flex® II Cable

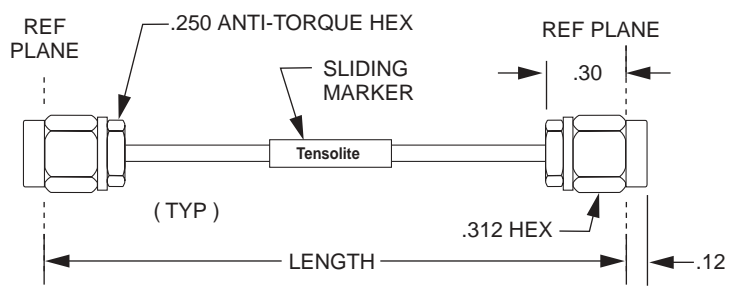

Tensolite Part Number	Length Inches	+ - Inches	Weight Ounces
1-3636-618-5204	4.00	0.05	1.1
1-3636-618-5205	5.00	0.10	1.3
1-3636-618-5206	6.00	0.10	1.5
1-3636-618-5208	8.00	0.10	2.0
1-3636-618-5212	12.00	0.15	2.9
1-3636-618-5218	18.00	0.15	4.3
1-3636-618-5224	24.00	0.15	5.7
1-3636-618-5236	36.00	0.20	8.4
1-3636-618-5248	48.00	0.25	11.1

1-3636-618-52XX
Your Length →

Semi-Flex® & Semi-Flex® Plus Cable Specifications

Features:

- These 50 ohm cables provide low loss and stable, highly shielded signal handling.
- Insertion loss dynamic stability < 10 dB @ 2 GHz/10 feet.
- Relative shielding effectiveness of < -90dB.
- Maximum operating frequency of 18 GHz.
- Semi-Flex® Plus is polyurethane jacketed.
- Available in 100 / 250 / 500 foot spools.

Materials: Semi-Flex®

- (A) Center conductor; Solid silver plated copper / copper weld steel.
- (B) Dielectric; Solid PTFE.
- (C) Interlayer; Copper / Polyester foil
- (D) Outer conductor; Tin filled high strength wire braid.

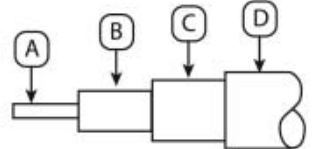

Part Number 7-1114-604-11
604 Semi-Flex® 0.047

Mechanical		Electrical	
A: Dia.	0.011	Max pull (Lbs)	20
B: Dia.	0.037	Max Op Volts	1000
C: Dia.	0.042	Max Watts	7
D: Dia.	0.047	Cap. pF/Ft	28.8
		Velocity %	70.5
Temp Range (C)	-50 / 200	Loss dB/100/Ft	190
Weight Lbs./Ft	0.0041	Delay nS/Ft	1.44

Part Number 7-1114-600-18
600 Semi-Flex® 0.086

Mechanical		Electrical	
A: Dia.	0.020	Max pull (Lbs)	30
B: Dia.	0.062	Max Op Volts	1500
C: Dia.	0.072	Max Watts	22
D: Dia.	0.087	Cap. pF/Ft	28.8
		Velocity %	70.5
Temp Range (C)	-50 / 200	Loss dB/100/Ft	116.7
Weight Lbs./Ft	0.011	Delay nS/Ft	1.44

Part Number 7-1114-601-18
601 Semi-Flex® 0.141

Mechanical		Electrical	
A: Dia.	0.036	Max pull (Lbs)	50
B: Dia.	0.117	Max Op Volts	1900
C: Dia.	0.127	Max Watts	60
D: Dia.	0.141	Cap. pF/Ft	28.8
		Velocity %	70.5
Temp Range (C)	-50 / 200	Loss dB/100/Ft	73.0
Weight Lbs./Ft	0.030	Delay nS/Ft	1.44

Materials: Semi-Flex® Plus

- (A) Center conductor; Stranded silver plated copper / copper weld steel.
- (B) Dielectric; Solid PTFE.
- (C) Interlayer; Copper / Polyester foil.
- (D) Outer conductor; Tin filled high strength wire braid.
- (E) Jacket; Clear Polyurethane.

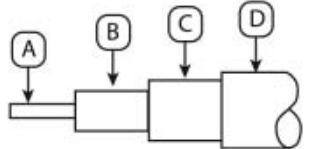

Part Number 7-1114-606-11
606 Semi-Flex® 0.250

Mechanical		Electrical	
A: Dia.	0.065	Max pull (Lbs)	80
B: Dia.	0.209	Max Op Volts	3000
C: Dia.	0.216	Max Watts	92
D: Dia.	0.245	Cap. pF/Ft	28.7
		Velocity %	70.5
Temp Range (C)	-50 / 80	Loss dB/100/Ft	48.0
Weight Lbs./Ft	0.091	Delay nS/Ft	1.44

Part Number 7-1114-620-18
620 Semi-Flex® Plus 0.086

Mechanical		Electrical	
A: Dia.	0.020	Max pull (Lbs)	30
B: Dia.	0.062	Max Op Volts	1500
C: Dia.	0.072	Max Watts	6
D: Dia.	0.087	Cap. pF/Ft	28.8
E: Dia.	0.120	Velocity %	70.5
Temp Range (C)	-50 / 80	Loss dB/100/Ft	116.7
Weight Lbs./Ft	0.019	Delay nS/Ft	1.44

Part Number 7-1114-621-18
621 Semi-Flex® Plus 0.141

Mechanical		Electrical	
A: Dia.	0.036	Max pull (Lbs)	50
B: Dia.	0.117	Max Op Volts	1900
C: Dia.	0.127	Max Watts	11
D: Dia.	0.141	Cap. pF/Ft	28.8
E: Dia.	0.173	Velocity %	70.5
Temp Range (C)	-50 / 80	Loss dB/100/Ft	73.0
Weight Lbs./Ft	0.045	Delay nS/Ft	1.44

How to order Standard RF/Microwave Assemblies

Designate the desired assembly by choosing from the available cables and connectors from the matrix to the far right. Insert the codes at the appropriate location as noted in the example. **Connector codes should be listed in increasing numerical sequence.**

Contact Tensolite for cables and connectors not shown.

ABBREVIATIONS
FEPFluorinated ethylene propylene
PURPolyurethane

5 ALL OTHER ASSEMBLIES

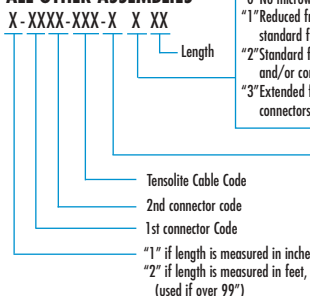

Specify
 0 No microwave test req. (Typical assemblies 1GHz) or less
 1 Reduced frequency microwave test requirement (Typically less than standard frequency of the cable and/or connectors used).
 2 Standard frequency microwave test requirement for the cable and/or connectors used).
 3 Extended frequency microwave test requirement for the cable and/or connectors used)

Specify
 1 Specific customer requirement when no customer drawing specification is available
 3 Standard product
 4 Standard product with at least one captive interface
 5 Standard product with at least one SMA Anti-Torque plug.
 P Standard delay matching to ± 4.2 Pico Seconds

Application Feature	Static Ground	Laboratory	Mobil Ground	Flight Hardware
1 Fixed	461,463,465, 561, 563, 565, 794, 604,600,601, 606, 620, 621, 650, 651, 617,618, 678	461,463,465, 561, 563, 565, 794, 604,600, 601, 606, 620, 621, 650, 651, 617,618, 678	461,463,465, 561, 563, 565, 794, 604,600, 601, 606, 620, 621, 650, 651, 617,618, 678	461,463, 604,600, 601, 606, 620, 621, 650, 651, 617,618, 678
Multiple flexures	676, 602, 504,524,511,510, 521,301	676, 602, 504,524,511,510, 521,301	676, 602, 504,524,511,510, 521,301	676, 602, 504,524,511,510, 521,301
Multiple connections	"Workhorse"	"Workhorse"	"Workhorse"	N/A

2 Expected lifetime connect/disconnect cycles				
Recommended Assembly Type				
676/678	600, 601, 604, 606, 617,618, 620, 621, 650, 651	461, 463, 465, 561, 563, 565, 794	301, 504, 510, 511, 521, 524	"Workhorse"
5	25	50	500	5000

All cable assemblies are labeled and 100% inspected to Tensolite's rigorous quality standards. Each item is tested for continuity, dielectric withstanding voltage and insulation resistance. The product is individually unit packaged and tagged for maximum protection and ease of identification. Phase matching within ±1.5° per GHz is available as a standard option on most cable assemblies.

3 Tensolite Cable Code	Description	Cable Diameter	Frequency Range	Jacket Material
461	Q-Flex®	.105	18 & 26.5	FEP
463	Q-Flex®	.163	18 & 26.5	FEP
465	Q-Flex®	.270	18	FEP
794	Q-Flex®	.105	40	FEP
561	Q-Flex Plus®	.115	18 & 26.5	PUR
563	Q-Flex Plus®	.180	18 & 26.5	PUR
565	Q-Flex Plus®	.290	18	PUR
604	Semi-Flex®	.047	18, 26.5 & 40	Tinned filled high strength wire braid
600	Semi-Flex®	.086	18, 26.5 & 40	Tinned filled high strength wire braid
601	Semi-Flex®	.141	18, 26.5 & 40	Tinned filled high strength wire braid
606	Semi-Flex®	.250	18	Tinned filled high strength wire braid
620	Semi-Flex® Plus	.112	18, 26.5 & 40	PUR
621	Semi-Flex® Plus	.180	18 & 26.5	PUR
650	Semi-Flex® Plus HT	.100	18, 26.5 & 40	FEP
651	Semi-Flex® Plus HT	.151	18 & 26.5	FEP
617	Semi-Flex II®	.086	20 & 40	Aluminum
618	Semi-Flex II®	.141	20 & 26.5	Aluminum
678	Semi-Rigid	.086	20 & 40	Copper
676	Semi-Rigid	.141	20 & 26.5	Copper
602	Semi-Rigid Low Loss	.141	20 & 26.5	Copper
504	Workhorse®	.200	18 & 26.5	FEP
524	Workhorse Plus®	.217	18	PUR
511	Ultra Flex	.123	8	PUR
510	Super Flex	.216	8	PUR
521	75 Ohm Super Flex	.216	3	PUR
301	Flexible Low Loss	.200	18	FEP

4 SERIES	CONNECTOR CODES															
	BNC	TNC	TYPE N	SMA	SSMA	SMB	SMC	MCX	smK	SMP	SSMP	BMA	1.85 mm	2.4 mm	3.5 mm	7 mm
Max Frequency in GHz	4	18	18	26.5	38	4	10	6	40	40	60	22	60	50	33	18
CONFIGURATION																
Plug	24	30	18	36	54	42	48	M6	K6	G6	R6	R1	V6	87	72	78
Right Angle Plug	25	31	19	37	55	43	49	M7	K7	G7	R7	N/A	V7	88	73	N/A
Jack	26	32	20	38	56	44	50	M8	K8	G8	R8	R2	V8	89	74	N/A
Panel Jack	27	33	21	39	57	45	51	M9	K9	G9	R9	R4	V9	90	75	N/A
Bulkhead Jack	28	34	22	40	58	46	52	M0	K0	N/A	N/A	R3	N/A	91	76	N/A

HOW TO USE THIS GUIDE

- 1** Choose best description of your application
- 2** Choose the lifetime connect/disconnect cycle
- 3** Choose your cable
- 4** Choose your connectors
- 5** Build your part number
- 6** Call Tensolite



Peltola Interconnect System

Peltola, a reliable, proven interconnect system

The Tensolite Peltola connector system uses the coaxial cable's center conductor for direct insertion into a receptacle. A press-fit action captures the cable shield, thus eliminating the need for any soldering or special crimping. Each interconnect assembly includes a close tolerance coaxial cable terminated to a male Peltola connector.

The Peltola receptacle is a direct fit replacement for typical SMB-type circuit board mounted receptacles.

The resultant interconnection provides excellent electrical characteristics with a significant cost advantage over typical SMB-type installations.

The Peltola RF interconnect system, designed by Tektronix, Inc., has been proven in the manufacture of its oscilloscopes and other instruments. Tensolite maintains the close-tolerance RF coaxial cable used in PELTOLA assemblies, plus the automated termination equipment for applying the connector.

The PELTOLA assemblies are available in both 50 Ω and 75 Ω impedance versions. PELTOLA cables are available in four standard versions. As shown in Table 1. The PELTOLA connector is available with a machined eyelet that seals the end of the cable, further improving the VSWR of the connection.

There are two PELTOLA receptacle choices, through-hole vertical mount and our NEW SMT right angle receptacle.

PELTOLA to panel-mount BNC is available.

In addition to assemblies with PELTOLA connectors on both ends, Tensolite's production facility can custom manufacture cable assemblies with a PELTOLA connector on one end, and the connector of your choice on the other.

Features:

- Offers a significant price advantage over typical assemblies
- VSWR compares very favorably with typical cable connectors
- Solderless connecting system, with 50 - 75 Ohm options
- SMT Right Angle Receptacle

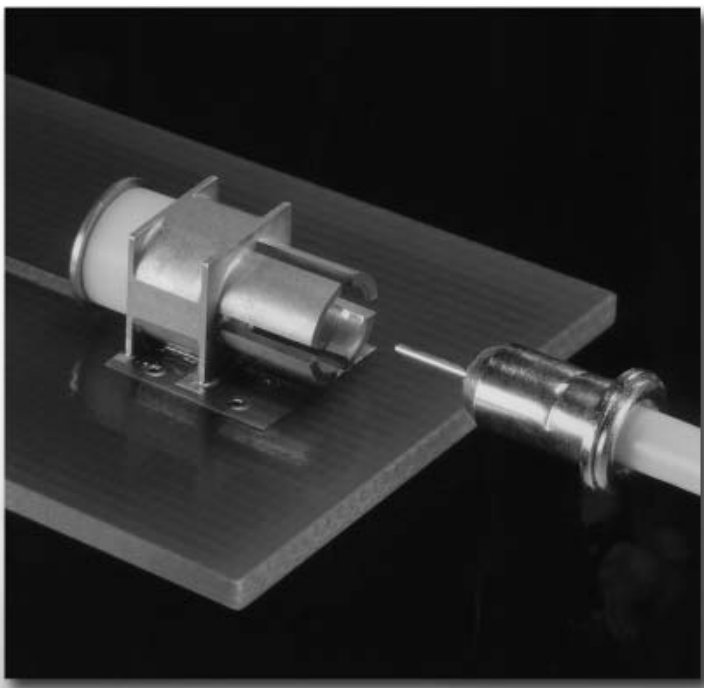

Peltola Interconnect System Data/Specifications

The PELTOLA RF Interconnect System from Tensolite is a proven, low-cost, electrically clean, reliable way to make RF cable connections between circuit boards or to back-side panels.

Electrical

Frequency:	DC - 3 Ghz
Nominal Impedance: Impedance:	50±5 Ohms 75±7.5 Ohms
VSWR Structural Return Loss	1.22:1 Maximum to 3 Ghz >20 dB to 3 Ghz
TDR	50 Ohm: 2.7 rho-picoseconds 75 Ohm: 2.2 rho-picoseconds

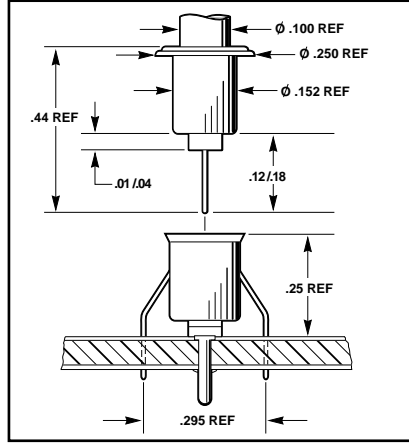

Standard PELTOLA Cable

CABLE PART NO. & CENTER COND.	AWG & O/D (in.)	DIELECTRIC & O/D (Inches)	SHIELD & PCT. of COVERAGE	JACKET & NOM. O/D (INCHES)	NOM. CAP. PF/FT.	IMPEDANCE (Ohms)	CABLE RATING
178-1179-66 Solid, Silver coated, copper covered steel	25 .018	Solid Polyethylene .058	100% Al Polyester 86% TC Braid	Black PP.100	30.8	50±2	-15/+105°C 300 V
175-1202-00 Solid, Silver coated, copper covered steel	25 .018	Solid Polyethylene .058	Tin-Coated Copper 88%	PVC .100	30.8	50±1	-15/+80°C 300 V
816-0198-00 Solid, Silver coated, copper covered steel	25 .018	FEP PTFE .055	Tin-Coated Copper 88%	FEP PTFE .100	28.4	50±2	15/+150°C 300 V
174-4390-66 Solid, silver coated, Copper Covered Steel	27 .0142	Cellular Polyethylene .061	Tin-coated Copper 88%	PVC .100	17.4	75±3	-15/+80°C 90 V

Material

Inner Contact	Brass
Outer Contact	Brass
Receptacle	Brass
SMT	Brass

Finishes

Inner Contact	Nickel/Gold Plate
Outer Contact	Nickel/Gold Plate
Receptacle	Nickel/Gold Plate
Receptacle	Nickel/Gold Plate

Mechanical

Contact Resistance Center Conductor Shield	MIL-STD-202F Method 307 1.5 milliohms 1.5 milliohms
Insertion Force Withdrawal Force	MIL-STD-1344A Method 2013.1 Initial 5 lbs. Initial 3 lbs.

Electrical

VSWR	Dependent upon length of the cable.
Typical VSWR for standard PELTOLA connector with 18" 50 ohm coax	Max 1.4 to 1 at 2 GHz
Typical VSWR for machined PELTOLA connector with 18" 50 ohm coax	Max 1.3 to 1 at 2 GHz

Environmental

Temperature Cycling -55 to +75°C	MIL-STD-810D Method 501.2, 502.2 (combination)
Temperature Storage 85°C/30 day	MIL-STD-202 Method 108A
Humidity Test	MIL-STD-202F Method 106E
Humidity Sulfide	Connectors were subjected to 24 hours of Hydrogen Sulfide at concentration of 5-10 PPM
Vibration 0.05" displacement/ 10 to 55 Hz	MIL-STD-202F Method 201A
Shock 100 gs	MIL-STD-202 Method 202D



Workhorse®, Workhorse® Plus & Low Loss Workhorse®

The Workhorse® Family is the result of Tensolite's years of assembly experience coupled with the demand for lower cost products. The Workhorse® assembly uses the time proven "504" cable, the Workhorse® Plus utilizes the "524" cable that provides better flexibility, and the Low Loss Workhorse® uses Tensolite's 301 Low Loss cable. All Workhorse® assemblies utilize our most rugged stainless steel connectors and a new extremely durable, yet cost effective attachment method.

18 and 26.5 GHz Cable Assemblies Features:

- Extremely durable and long lasting connector attachment method
- Excellent high frequency response
- Phase stable with flexure
- Standard lengths in stock

Type N Male to Type N Male on Workhorse® Cable

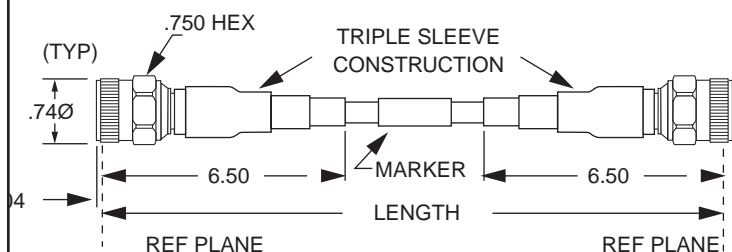

Tensolite Part Number	Length Inches	+ - Inches	Weight Ounces
WHU18-1818-024	24.00	0.25	5.3
WHU18-1818-030	30.00	0.30	5.6
WHU18-1818-036	36.00	0.36	5.9
WHU18-1818-042	42.00	0.42	6.3
WHU18-1818-048	48.00	0.48	6.6
WHU18-1818-072	72.00	0.72	8.0
WHU18-1818-120	120.00	1.20	10.8

WHU18-1818-XXX
Your Length

Type N to SMA Male on Workhorse® Cable

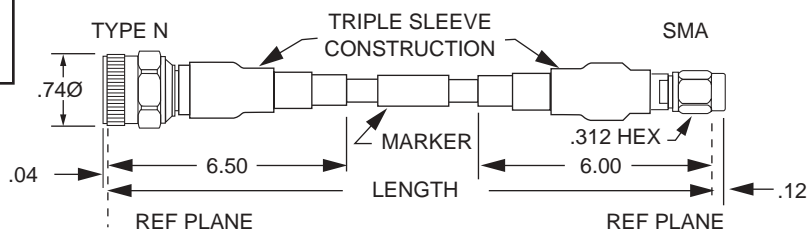

Tensolite Part Number	Length Inches	+ - Inches	Weight Ounces
WHU18-1836-024	24.00	0.25	4.8
WHU18-1836-030	30.00	0.30	5.1
WHU18-1836-036	36.00	0.36	5.4
WHU18-1836-042	42.00	0.42	5.8
WHU18-1836-048	48.00	0.48	6.1
WHU18-1836-072	72.00	0.72	7.5
WHU18-1836-120	120.00	1.20	10.3

WHU18-1836-XXX
Your Length

SMA Males on Workhorse® Cable

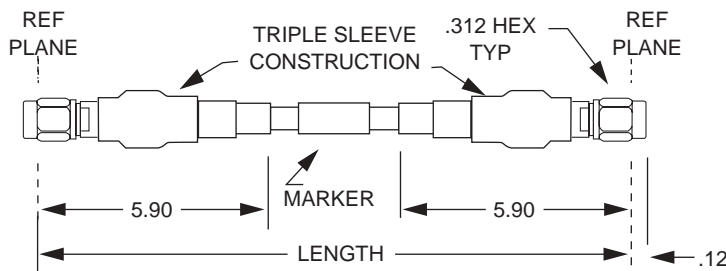

Tensolite Part Number	Length Inches	+ - Inches	Weight Ounces
WHU18-3636-024	24.00	0.25	3.7
WHU18-3636-030	30.00	0.30	4.0
WHU18-3636-036	36.00	0.36	4.3
WHU18-3636-042	42.00	0.42	4.7
WHU18-3636-048	48.00	0.48	5.0
WHU18-3636-072	72.00	0.72	6.4
WHU18-3636-120	120.00	1.20	9.2

WHU18-3636-XXX
Your Length

Workhorse® Plus

Type N Male to N Male on Workhorse® Plus Cable

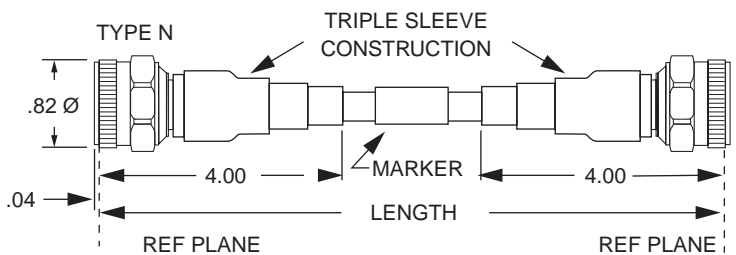

Tensolite Part Number	Length Inches	+ - Inches	Weight Ounces
1-1818-524-WH 24	24.00	0.25	5.4
1-1818-524-WH 30	30.00	0.30	5.8
1-1818-524-WH 36	36.00	0.36	6.1
1-1818-524-WH 39	39.4	0.39	6.3
1-1818-524-WH 48	48.00	0.48	6.9
1-1818-524-WH 72	72.00	0.72	8.4
2-1818-524-WH 10	120.00	1.20	11.4

1-1818-524-WH XX
Your Length →

Type N Male to Hybrid SMA Male on Workhorse® Plus Cable

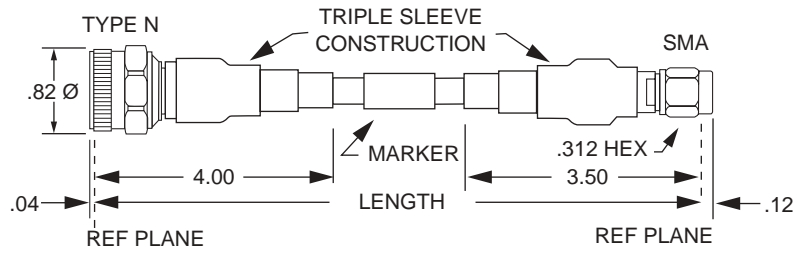

Tensolite Part Number	Length Inches	+ - Inches	Weight Ounces
1-1836-524-WH 24	24.00	0.25	5.4
1-1836-524-WH 30	30.00	0.30	5.8
1-1836-524-WH 36	36.00	0.36	6.1
1-1836-524-WH 42	39.00	0.39	6.3
1-1836-524-WH 48	48.00	0.48	6.9
1-1836-524-WH 72	72.00	0.72	8.4
2-1836-524-WH 10	120.00	1.20	11.4

1-1836-524-WH XX
Your Length →

Hybrid SMA Male to SMA Male on Workhorse® Plus Cable

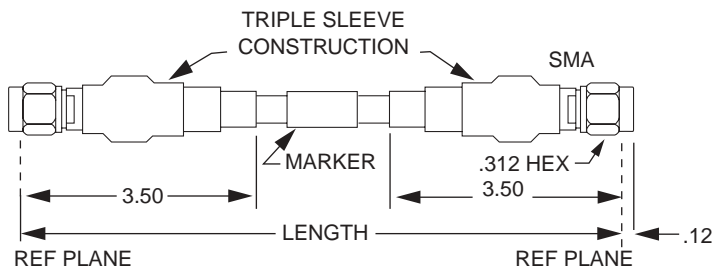

Tensolite Part Number	Length Inches	+ - Inches	Weight Ounces
1-3636-524-WH 24	24.00	0.25	5.4
1-3636-524-WH 30	30.00	0.25	5.8
1-3636-524-WH 36	36.00	0.36	6.1
1-3636-524-WH 42	42.00	0.42	6.5
1-3636-524-WH 48	48.00	0.48	6.9
1-3636-524-WH 72	72.00	0.72	8.4
2-3636-524-WH 10	120.00	1.20	11.4

1-3636-524-WH XX
Your Length →

Low Loss Workhorse®

Type N Males on Low Loss Workhorse® Cable

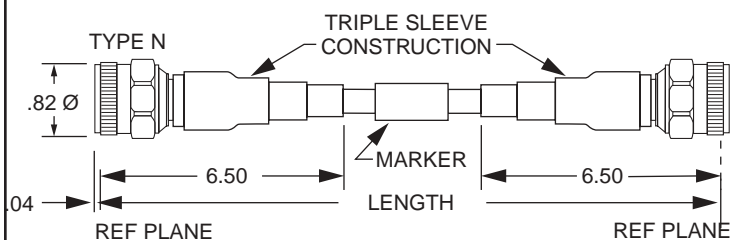

Tensolite Part Number	Length Inches	+ - Inches	Weight Ounces
WLU18-1818-024	24.00	0.25	4.6
WLU18-1818-030	30.00	0.30	4.9
WLU18-1818-036	36.00	0.36	5.2
WLU18-1818-042	42.00	0.42	5.4
WLU18-1818-048	48.00	0.48	5.7
WLU18-1818-072	72.00	0.72	6.8
WLU18-1818-120	120.00	1.20	9.1

WLU18-1818-XXX
Your Length

Type N and SMA Males on Low Loss Workhorse® Cable

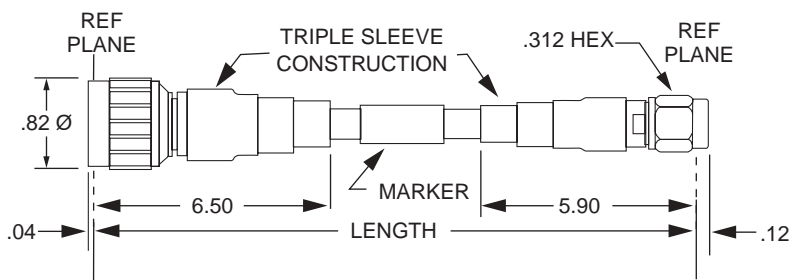

Tensolite Part Number	Length Inches	+ - Inches	Weight Ounces
WLU18-1836-024	24.00	0.25	4.5
WLU18-1836-030	30.00	0.30	4.8
WLU18-1836-036	36.00	0.36	5.1
WLU18-1836-042	42.00	0.42	5.3
WLU18-1836-048	48.00	0.48	5.6
WLU18-1836-072	72.00	0.72	6.7
WLU18-1836-120	120.00	1.20	9.0

WLU18-1836-XXX
Your Length

SMA Males on Low Loss Workhorse® Cable

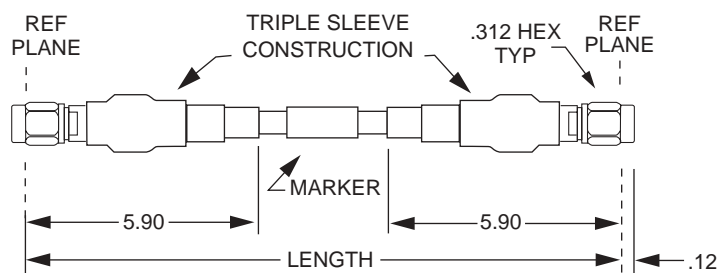

Tensolite Part Number	Length Inches	+ - Inches	Weight Ounces
WLU18-3636-024	24.00	0.25	3.4
WLU18-3636-030	30.00	0.30	3.7
WLU18-3636-036	36.00	0.36	4.0
WLU18-3636-042	42.00	0.42	4.2
WLU18-3636-048	48.00	0.48	4.5
WLU18-3636-072	72.00	0.72	5.6
WLU18-3636-120	120.00	1.20	7.9

WLU18-3636-XXX
Your Length

The Armored Workhorse® Series

The Armored Workhorse® features a stainless steel, crush-proof jacket that protects the Tensolite "504" cable from everyday wear and tear associated with a lab environment. Combined with our rugged stainless steel connector series, this provides an extremely durable test cable for high temperature testing and very high volume production lines.

Features:

- "Armored" for even greater protection
- Excellent high frequency response
- Phase stable with flexure
- Standard lengths in stock

Type N Males on Armored Workhorse® Cable

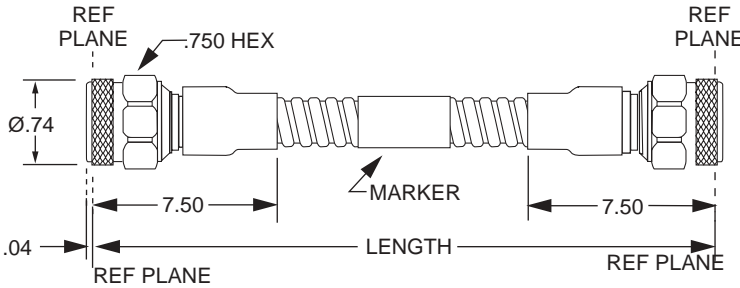

Tensolite Part Number	Length Inches	+ - Inches	Weight Ounces
WHA18-1818-024	24.00	0.25	7.1
WHA18-1818-030	30.00	0.30	7.8
WHA18-1818-036	36.00	0.36	8.6
WHA18-1818-042	42.00	0.42	9.4
WHA18-1818-048	48.00	0.48	10.2
WHA18-1818-072	72.00	0.72	13.4
WHA18-1818-120	120.00	1.20	19.8

WHA18-1818-XXX
Your Length

Type N Male to SMA Male on Armored Workhorse® Cable

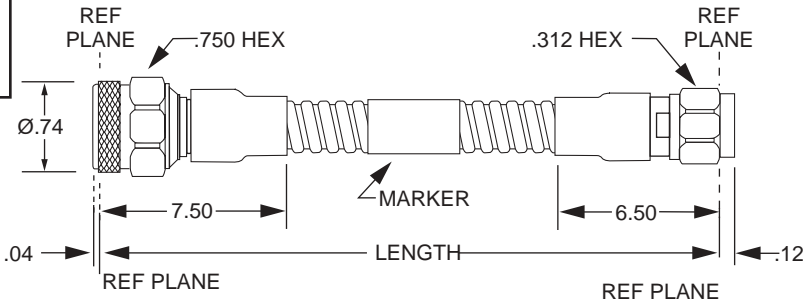

Tensolite Part Number	Length Inches	+ - Inches	Weight Ounces
WHA18-1836-024	24.00	0.25	6.6
WHA18-1836-030	30.00	0.30	7.3
WHA18-1836-036	36.00	0.36	8.1
WHA18-1836-042	42.00	0.42	8.9
WHA18-1836-048	48.00	0.48	9.7
WHA18-1836-072	72.00	0.72	12.9
WHA18-1836-120	120.00	1.20	19.3

WHA1818-1836-XXX
Your Length

SMA Males on Armored Workhorse® Cable

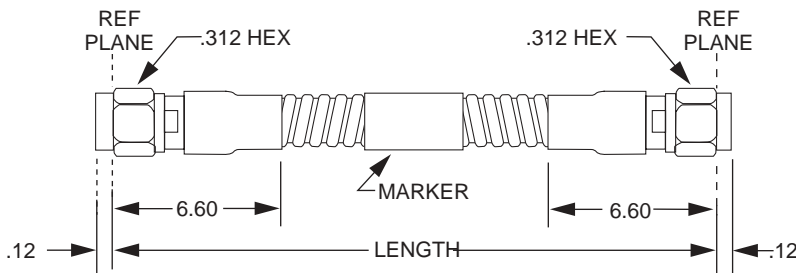

Tensolite Part Number	Length Inches	+ - Inches	Weight Ounces
WHA18-3636-024	24.00	0.25	6.2
WHA18-3636-030	30.00	0.30	6.9
WHA18-3636-036	36.00	0.36	7.7
WHA18-3636-042	42.00	0.42	8.5
WHA18-3636-048	48.00	0.48	9.3
WHA18-3636-072	72.00	0.72	12.5
WHA18-3636-120	120.00	1.20	18.9

WHA18-3636-XXX
Your Length

Low Cost, Low Loss 18GHz 30I Cable Assemblies

Tensolite's newly developed LOW COST, LOW LOSS "30I" cable ends the 3-way compromise users face when defining insertion loss for higher frequency, flexible cable assemblies. Historically, low loss meant high price or reduced flexibility. "30I" cable is a microporous PTFE design in .200" diameter that offers all three advantages: low loss, low price and excellent flexibility.

"30I" LOW COST, LOW LOSS assemblies help the designer achieve system performance goals while retaining the flexibility of braided cables. Alternatively, "30I" cables may be used to replace .141" diameter semi-rigid or .250" diameter corrugated copper cables.

Features:

- Low insertion loss
- Microporous PTFE dielectric
- Increased flexibility
- Standard lengths in stock

SMA Male to SMA Male on 30I Cable

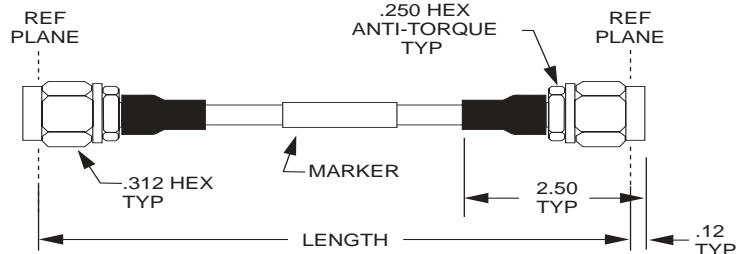

Tensolite Part Number	Length Inches	+ - Inches	Weight Ounces
1-3636-301-3206	6.00	0.25	1.5
1-3636-301-3212	12.00	0.25	1.8
1-3636-301-3218	18.00	0.25	2.2
1-3636-301-3224	24.00	0.25	2.5
1-3636-301-3248	48.00	0.48	3.8

1-3636-301-32XX
Your Length

Type N Male to SMA Male on 30I Cable

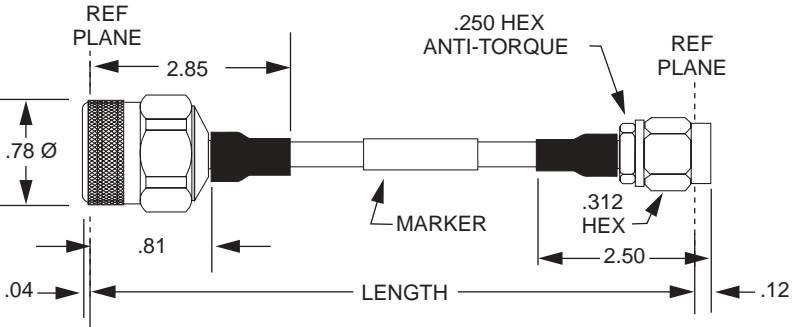

Tensolite Part Number	Length Inches	+ - Inches	Weight Ounces
1-1836-301-3206	6.00	0.25	1.5
1-1836-301-3212	12.00	0.25	1.8
1-1836-301-3218	18.00	0.25	2.2
1-1836-301-3224	24.00	0.25	2.5
1-1836-301-3236	36.00	0.36	3.1
1-1836-301-3248	48.00	0.48	3.8

1-1836-301-32XX
Your Length

Type N Male to Type N Male on 30I Cable

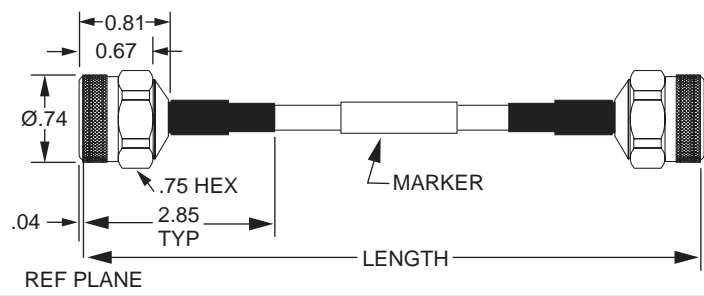

Tensolite Part Number	Length Inches	+ - Inches	Weight Ounces
1-1818-301-3206	6.00	0.25	2.4
1-1818-301-3212	12.00	0.25	2.8
1-1818-301-3218	18.00	0.25	3.1
1-1818-301-3224	24.00	0.25	3.5
1-1818-301-3236	36.00	0.36	4.2
1-1818-301-3248	48.00	0.48	4.9

1-1818-301-32XX
Your Length

TNC Male to TNC Male on 30I Cable

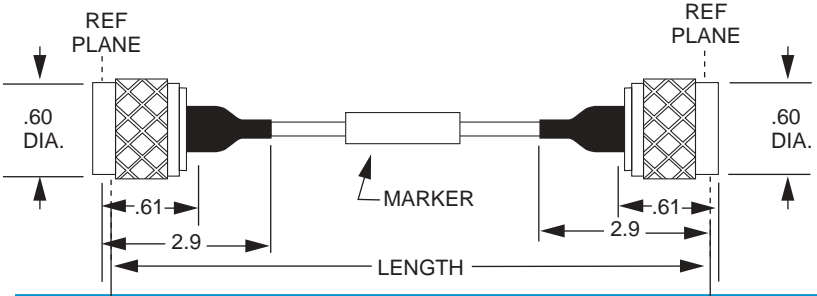

Tensolite Part Number	Length Inches	+ - Inches	Weight Ounces
1-3030-301-3206	6.00	0.05	2.4
1-3030-301-3212	12.00	0.10	2.7
1-3030-301-3218	18.00	0.15	3.0
1-3030-301-3224	24.00	0.15	3.4
1-3030-301-3236	36.00	0.15	4.0
1-3030-301-3248	48.00	0.20	4.6

1-3030-301-32XX
Your Length

Tensolite

Call: 877-890-7483 Website: www.tensolite.com

A CARLISLE Company



High-Density Cable Assemblies

HDSI® High-Density Shielded Interconnect

Low-profile, microminiature, ribbonized coaxial and differential cable assemblies that feature TYCO Electronics Mictor® and Samtec's QTE and QSE coaxial, and differential series connectors. These low profile, high-density assemblies offer optimal signal integrity achieved through matched impedance cable assemblies. HDSI® assemblies are ideal for high-speed digital or analog signal transmission in high-end servers, telecommunication switches / routers, and Automatic Test Equipment.

HM - 2mm Hard Metric Interconnect-to-Backplane

A high-density, high-speed modular system (that complies with IEC 1076-4-101) for cable to board applications with minimum crosstalk and signal rise times measured in picoseconds. The HM system is a modular 2mm signal-contact-pitch cable connector with pins arranged in stackable 1 X 5 wafers for optimum performance.

The system is configurable to any shielding location and can utilize any coax cable with a max. O.D. of .068".

HDM® - 2mm High-Density Interconnect

HDM® Interconnect Systems featuring 2mm cable connectors - bring high-density, high-speed, cost effective I/O directly to Teradyne Backplane connectors. Delivering signals at rates as high as 1 Gbit/sec. The HDM® system is a modular 2mm signal-contact-pitch cable connector with pins arranged in stackable 1 X 6 wafers with a center to center spacing of 2mm.

The improved HDM design reduces the impedance discontinuity through the wafer for improved performance.

.100" Pitch System

Miniature, high-density, cost effective, stackable molded cable assemblies – backplane interconnects and jumpers. Featuring low-loss, high-speed coaxial and differential cables. They are available in 1x2 and 1x3 stackable wafers with a center to center spacing of .100".



Custom Solutions:

Tensolite's custom Spring Pin designs can be engineered for maximum pin density and electrical performance maintaining signal integrity for higher data rates.

HDM® is a registered trademark of Teradyne, Inc.
Mictor® is a registered trademark of TYCO.
HDSI® is a trademark of Tensolite.



HIGH-DENSITY, HIGH-SPEED 2MM BOARD-TO-BACKPLANE INTERCONNECT SYSTEM

Mechanical

On-Center Spacing	2.0 mm
Mating Pin Length	3 to 8 mm
Mating Pin Dimensions	0.40 mm X 0.40 mm
Insertion Force, Per Contact	0.75 N, max.
Withdrawal Force, Per Contact	0.15 N, min.
Normal Force, Per Contact	0.70 N
Cable Retention Force	22 N
Durability (Insertions / Withdrawals)	250 cycles

Electrical

Insulation Resistance	100 MΩ, min.
Dielectric Withstanding Voltage	500 V
Voltage Rating	250 VAC
Current Rating, @ 70°C Per Contact	1.0 A
Contact Resistance	20 mΩ, min.

Materials

Shield	Beryllium Copper
Contacts	Beryllium Copper
Dielectric, per UL 94V-0	Glass-Filled Modified PET

Plating

Contacts — Ni all over	1.27 μm, min
Au all over	1.27 μm



HARD METRIC - 2MM HIGH-SPEED CABLE INTERCONNECT-TO-BACKPLANE SYSTEM

Mechanical

On-Center Spacing	2.0 mm
Mating Pin Length	4 to 6 mm
Mating Pin Dimensions	0.35 mm X 0.45 mm
Insertion Force, Per Contact	0.75 N, max.
Withdrawal Force, Per Contact	0.15 N, min.
Normal Force, Per Contact	0.70 N
Cable Retention Force	22 N
Durability (Insertions / Withdrawals)	250 cycles

Electrical

Insulation Resistance	100 MΩ, min.
Dielectric Withstanding Voltage	500 V
Voltage Rating	250 VAC
Current Rating, @ 70°C Per Contact	1.0 A
Contact Resistance	20 mΩ, min.

.100" Pitch

MINIATURE, HIGH-PERFORMANCE INTER-CONNECT-TO-BACKPLANE & JUMPER CABLE ASSEMBLIES

Socket Connectors

1 x 2 1 x 3

50 & 75-ohm Coaxial	X	X
100-ohm Shielded Twisted Pair		X
100-ohm Twin-ax		X

Mechanical

On-Center Spacing	0.100"
Mating Pin Length	0.275", max.
Insertion Force, Per Contact	0.138 N, max.
Insertion Force, Per Contact	0.75 N, max.
Withdrawal Force, Per Contact	0.738 N., min.
Durability (Insertions / Withdrawals)	250 cycles

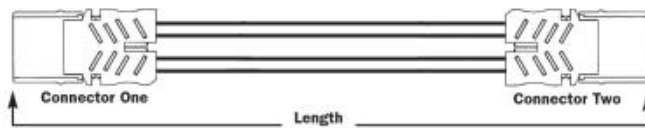
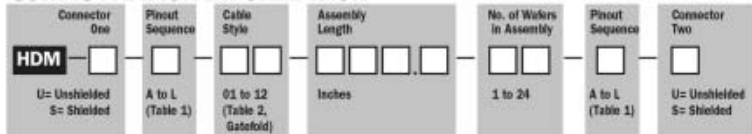

TABLE I - AVAILABLE PINOUT SEQUENCES

WAFER POSITION	A	B	C	D	E	F	G	H	I	J	K	L
1	S	G	S	-	G	-	S	G	S	G	S	G
2	S	S	S	-	S	-	G	S	G	S	G	S
3	G	S	G	-	S	-	S	G	-	-	-	-
4	S	G	-	S	-	G	G	S	-	-	-	-
5	S	S	-	S	-	S	S	G	S	G	-	-
6	G	S	-	G	-	S	G	S	G	S	-	-

S=Signal G=Ground

CONFIGURATION INFORMATION



HDM® is a registered trademark of Teradyne, Inc.

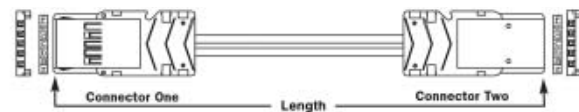

TABLE I - AVAILABLE PINOUT SEQUENCES

WAFER POSITION	A	B	C	D	E	F	G	H	J	K	L	M	N
Z	+	+	+	+	+	+	+	+	+	+	+	+	+
A	S	S	-	S	G	S	-	G	-	S	S	S	
B	S	S	-	G	S	G	-	S	-	S	S	S	
C	G	G	G	-	-	-	-	-	-	-	-	S	
D	S	-	S	S	G	-	S	-	G	S	S	S	
E	S	-	S	G	S	-	S	-	S	S	G	S	
F	+	+	+	+	+	+	+	+	+	+	+	+	+

S = Signal G = Ground - = No Connection + = With (optional) inter-module shields
Z and F rows are committed to ground through one or more additional wafer positions
Note: Z and F do not apply to 1x5 wafers

CONFIGURATION INFORMATION

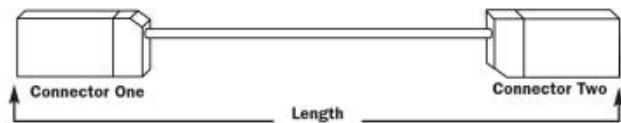
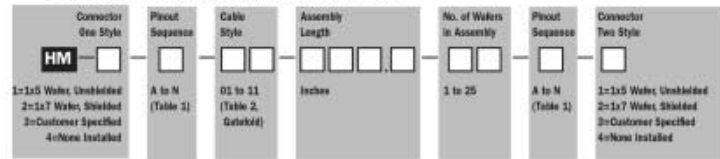
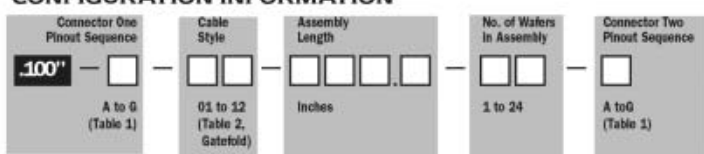

TABLE I - .100-INCH SOCKET CONNECTOR PINOUTS

WAFER POSITION	A	B	C	D	E	WAFER POSITION	F	G
1X3	S	G	S	S	-	1X2	S	G
	S	S	-	G	S		G	S
	G	S	G	-	G			

S=Signal G=Ground

CONFIGURATION INFORMATION





High Density Cable Styles

Table A – Standard Cable Styles

Cable Style	Wire Construction	Description	Conductor/Drain AWG	Conductor/Drain Standing	Time Delay ns/ft	Attenuation (db/100ft)	DC Resistance ohms/1,000 ft	Drawing Assembly P/N
01		100 Ω parallel pair	26/28	Solid	1.2	100mHz (nom.) - 11.1 400mHz (nom.) - 22.4	40.0	654-56012-00
02		100 Ω parallel pair	26/30	7 strands	1.2	100mHz (nom.) - 10.0 400mHz (nom.) - 20.3	38.0	654-56006-00
03		100 Ω parallel pair	28/28	Solid	1.2	100mHz (nom.) - 14.1 400mHz (nom.) - 28.3	64.0	654-56008-00
04		100 Ω parallel pair	28/28	7 strands	1.2	100mHz (nom.) - 12.7 400mHz (nom.) - 25.5	60.0	654-56009-00
05		100 Ω parallel pair	30/30	Solid	1.2	100mHz (nom.) - 17.6 400mHz (nom.) - 35.5	102.0	654-56010-00
06		100 Ω parallel pair	30/30	7 strands	1.2	100mHz (nom.) - 15.6 400mHz (nom.) - 31.5	93.0	654-56011-00
07		50 Ω coax	26/26	7 strands	1.2	100mHz (nom.) - 14.0 400mHz (nom.) - 33.0	38.0	654-55035-00
08		50 Ω coax	28/28	7 strands	1.2	100mHz (nom.) - 16.0 400mHz (nom.) - 37.0	60.0	654-55039-00
09		50 Ω coax	26	Solid	1.2	100mHz (nom.) - 8.5 400mHz (nom.) - 17.4	38.0	654-55041-00
10		75 Ω coax	30/30	7 strands	1.2	100mHz (nom.) - 12.5 400mHz (nom.) - 29.5	93.0	654-55037-00
11		Special Customer Specified Cable Style						

Wire constructions utilize an ePTFE dielectric, aluminum-polyester shield with drain or braided shield and FEP Jacket

Introducing Tensolite's HDSI®, High-Density Shielded Interconnects, perfect for a wide variety of demanding, high-speed applications:

HDSI® assemblies are ideal for high-speed digital or analog signal transmission in high-end servers, telecommunication switches/routers, and Automatic Test Equipment.

Tensolite High-Density Shielded Interconnects, are low profile, micro-miniature, ribbonized coax cable or Differential Pair assemblies featuring Samtec's QTE and QSE single-ended or differential series connectors. HDSI® assemblies are extremely flexible, allow tight bend radii, and are easy to route in tight spaces. These low profile, high-density interconnects offer optimal signal integrity, achieved through matched impedance cable assemblies. Tensolite assemblies are built to order to meet your bulkhead or board interconnect requirement. Specify number of signal lines, edge-mount or surface-mount connector style, plug or receptacle, and overall length.

Ideal for a wide variety of demanding, high-speed applications:

- High-End Servers
- Backplane to Backplane
- Production or Benchtop Testing
- Data Telecom Switches
- Extender Cables
- I/O Assemblies

See our web site for Technical Data Sheets www.tensolite.com

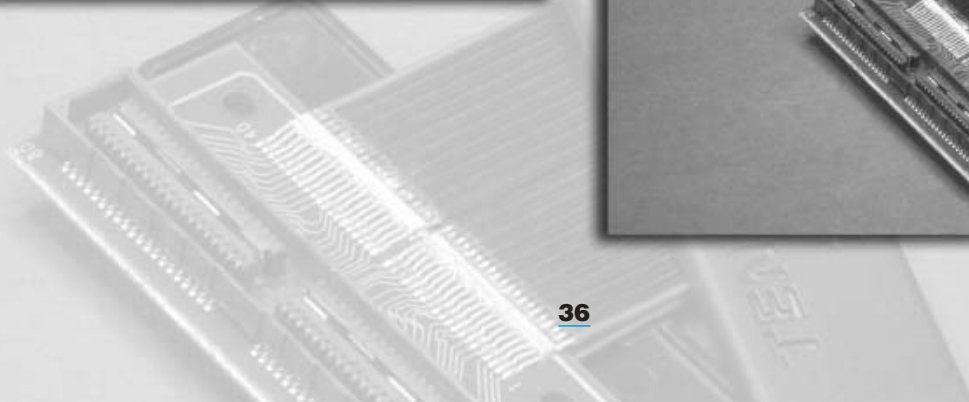
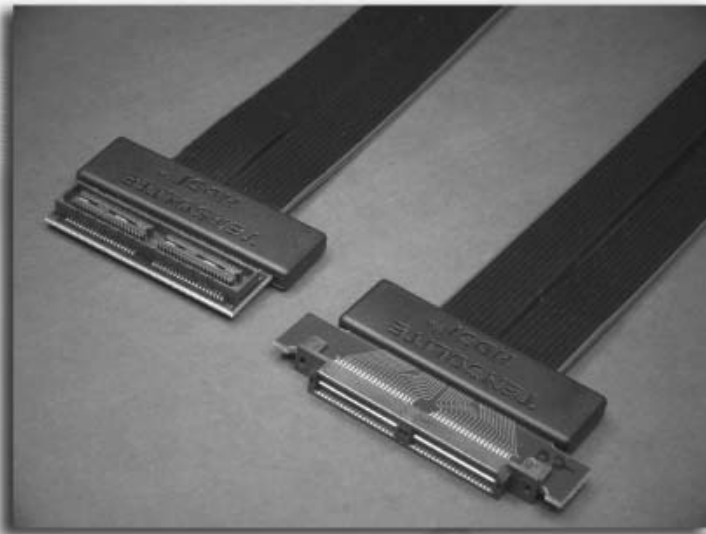

HDSI® DP™ (Differential Pair)

Tensolite's High-Density Shielded Interconnect – Differential Pair (HDSI-DP™) offers all of the advantages of differential signaling without the increased space requirements normally associated with this signaling method.

The assemblies employ Samtec's QSE/QTE connectors and results in up to 16 pairs per inch. HDSI-DP™ assemblies use Tensolite's ePTFE 30 Awg, 100 ohm, ultra-low skew, differential cable with both conductors coupled within a common shield.

HDSI-DP™ matched impedance assemblies are available in configurations ranging from 7 to 70 pairs, plug or receptacle, edge-mount or surface-mount connectors, and custom lengths. HDSI-DP™ assemblies exhibit superior noise immunity and are ideal for LVDS applications.

Ideal for a wide variety of demanding, high-speed applications:

- High-End Servers
- Backplane to Backplane
- Production or Benchtop Testing
- Data Telecom Switches
- Extender Cables
- I/O Assemblies

See our web site for Technical Data Sheets www.tensolite.com

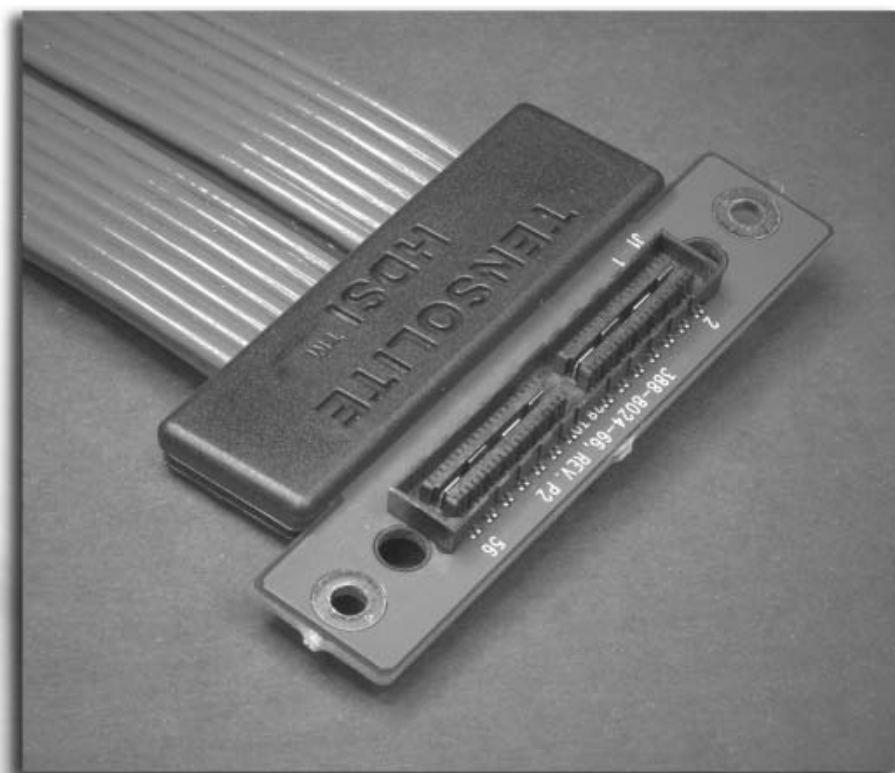

HDSI® & HDSI DP™ Part Numbering System

Numbering Format

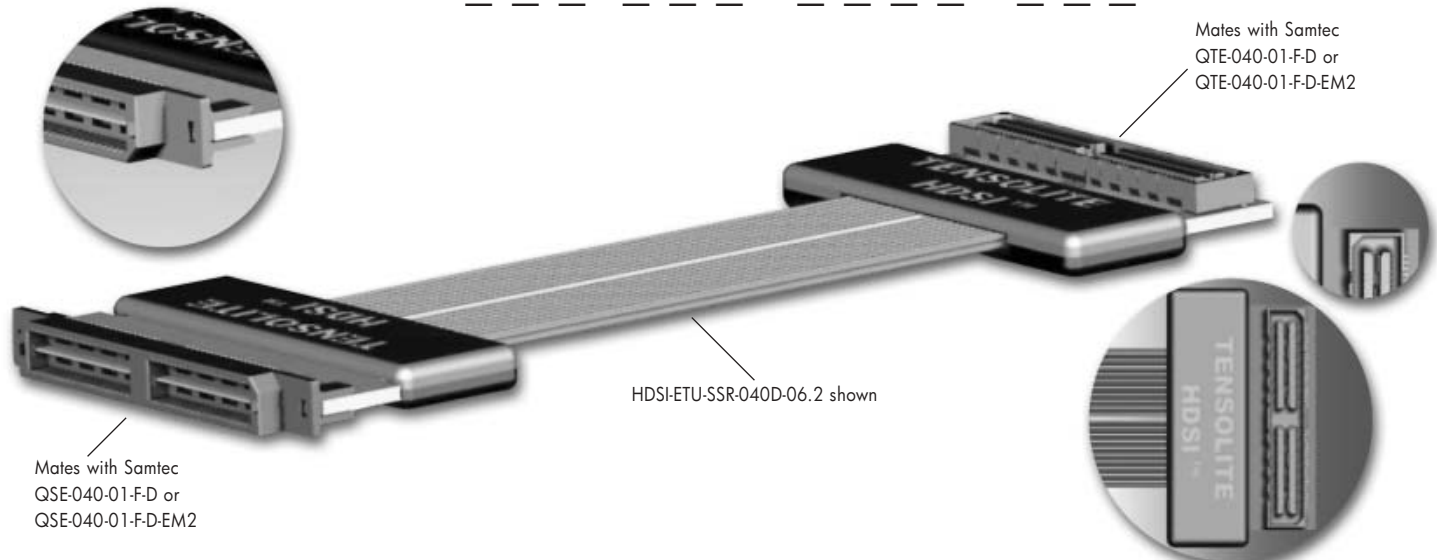
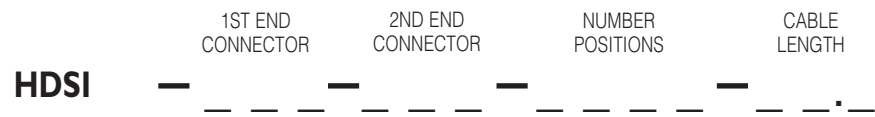

Connector Style

(Samtec QSE/QTE Series) 1st end connector is always considered to be up.
 * Down or up is relative to orientation of 1st end connector

X X X

Polarizer

SURFACE MOUNT: R - CONNECTOR UP POLARIZER OUT FROM CENTER
 P - CONNECTOR UP POLARIZER IN TOWARDS CENTER
 E - CONNECTOR DOWN POLARIZER OUT FROM CENTER
 F - CONNECTOR DOWN POLARIZER IN TOWARDS CENTER

EDGE MOUNT: U - POLARIZER FACING UP*
 D - POLARIZER FACING DOWN*

Connector Type

S- (QSE) SOCKET
 T- (QTE) PLUG

Connector Style

S- SURFACE MOUNT
 E- EDGE MOUNT

- STEP-1: Determine style of 1st end connector**
 (Connector orientation on 1st end is always considered to be "UP")
- STEP-2: Determine style of 2nd end connector**
 (Connector orientation of 2nd end is relative to orientation of 1st end)
- STEP-3: Number of positions**
 (Indicate **S** for single or **D** for double populated)

Single Ended Applications

-020X-	020S=	20 Positions	020D=	40 Positions
-040X-	040S=	40 Positions	040D=	80 Positions
-060X-	060S=	60 Positions	060D=	120 Positions
-080X-	080S=	80 Positions	080D=	160 Positions
-100X-	100S=	100 Positions	100D=	200 Positions

Differential Applications

-014X-	014S=	7 Pairs	014D=	14 Pairs
-028X-	028S=	14 Pairs	028D=	28 Pairs
-042X-	042S=	21 Pairs	042D=	42 Pairs
-056X-	056S=	28 Pairs	056D=	56 Pairs
-070X-	070S=	35 Pairs	070D=	70 Pairs

See our web site for
 Technical Data Sheets
www.tensolite.com

STEP-4: Determine cable length

(To the nearest 10th of an inch. Length tolerance is ±2%)

NOTE: Standard plating is gold flash. Additional plating options available.
 Custom connector and assembly options also available.
 CALL FOR DETAILS.

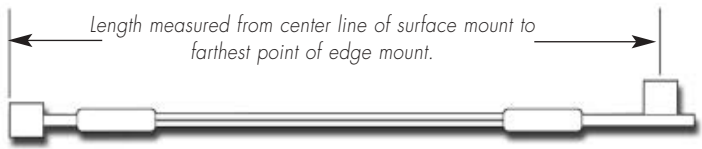



HDSI® Edge Mount to Edge Mount Technical Data Test Results

Ribbonized Coax—Electrical Specifications		
Impedance, Nominal:	50	Ohms
Center Conductor DCR (MAX):	0.60	Ohms/Foot
Ribbonized Conductor Ampacity:	0.2	Amps
Coax Shield DCR (MAX):	0.22	Ohms/Foot
Capacitance Nominal:	29.0	pF/Foot
Velocity of Propagation, Nominal:	70	%
Electrical Delay:	1.45	nS/Foot
Electrical Delay:	121	pS/Inch
UL Style:	1354	
UL Voltage:	30	Volts
UL Temperature:	80	Degrees C

Ribbonized Coax—Mechanical Specifications		
Configuration:	20	Coaxes
Center Conductor:	38	AWG
Height:	0.031	+/- .002 Inches
Pitch:	0.025	+/- .002 Inches
Width (20 Conductors):	0.500	+/- .008 Inches
Span (20 Conductors):	0.450	+/- .008 Inches

Connector—Mechanical Specifications		
QSE-040-01-F-D-EM2	Samtec 0.80mm Edge Mount Socket	
QTE-040-01-F-D-EM2	Samtec 0.80mm Edge Mount Plug	

HDSI Assembly - Electrical Specifications: (Summary)		
Insertion Loss:	See Table Below	
Risetime:	See Table Below	
Bandwidth:	See Table Below	
Group Skew:	See Table Below	
Adjacent Pair Skew:	See Table Below	
VSWR:	1.5:1 <1 GHz	
Crosstalk (NEXT):	<10% Up to 250 MHz	
Crosstalk (FEXT):	<10% Up to 500 MHz	

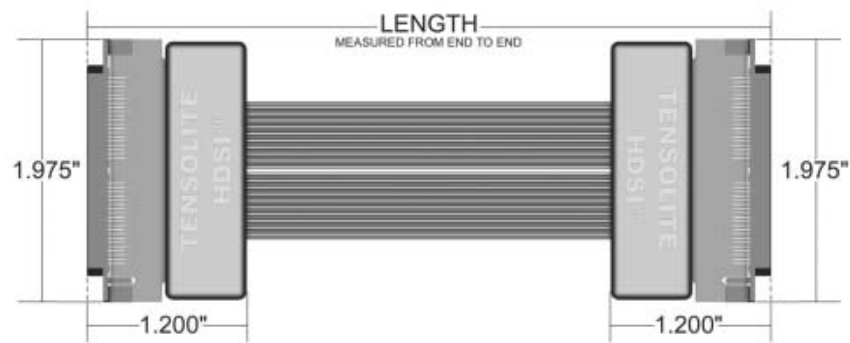

HDSI-ETU-ETU-040D-XX.X

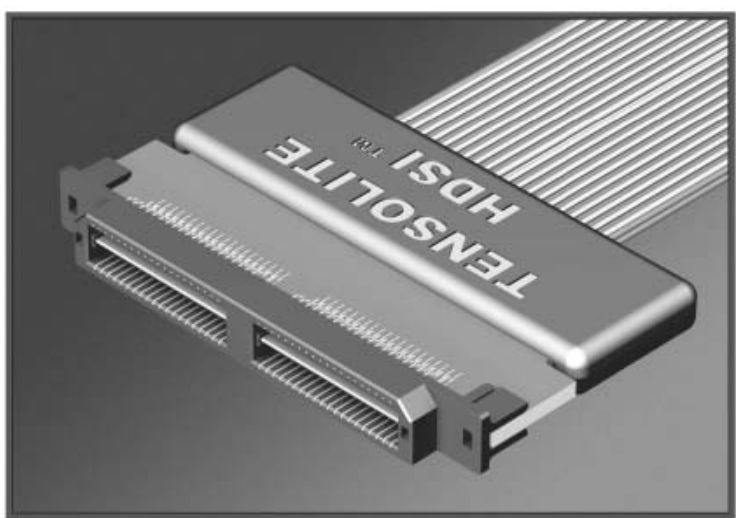

See our web site for further Technical Data Sheets www.tensolite.com

Length Inches	Length Feet	Length Meters	Typical Insertion Loss in dB at Freq. (in MHz.)					Max. Group Skew psec	Max. Adj. Pair Skew psec	BW -3 dB MHz	Risetime -3 dB BW psec
			up to 100	100 to 250	250 to 500	500 to 750	750 to 1000				
3.94	0.328	0.10	0.05	0.22	0.46	0.69	0.85	38	22	1457	240
9.84	0.820	0.25	0.09	0.48	0.95	1.36	1.65	50	28	998	351
12.00	1.000	0.30	0.10	0.69	1.27	1.82	2.20	54	30	858	408
19.69	1.641	0.50	0.15	0.94	1.65	2.28	2.76	62	38	722	485
29.53	2.461	0.75	0.22	1.25	2.12	2.87	3.42	74	49	620	565
39.37	3.281	1.00	0.29	1.62	2.61	3.51	4.17	86	60	544	643
49.21	4.101	1.25	0.35	2.02	3.21	4.25	5.07	98	71	476	735
59.05	4.921	1.50	0.42	2.40	3.74	4.93	5.82	110	82	424	825

Length Inches	Length Feet	Length Meters	Typical Crosstalk (Next) Freq. (in MHz.)				Typical Crosstalk (Fext) Freq. (in MHz.)			
			up to 250	250 to 500	500 to 750	750 to 1000	Up to 250	250 to 500	500 to 750	750 to 1000
3.94	0.328	0.10	8.5%	16.5%	23.0%	27.0%	5.8%	8.5%	10.0%	12.0%
9.84	0.820	0.25	8.5%	16.5%	22.0%	26.0%	5.3%	7.8%	9.2%	10.9%
12.00	1.000	0.30	8.5%	16.0%	21.5%	25.5%	5.3%	7.4%	8.9%	10.7%
19.69	1.641	0.50	8.5%	15.5%	20.0%	25.0%	4.9%	7.2%	8.3%	9.8%
29.53	2.461	0.75	8.0%	14.5%	19.5%	23.5%	4.4%	6.5%	7.5%	8.7%
39.37	3.281	1.00	7.5%	13.5%	18.0%	21.0%	3.9%	5.8%	6.6%	7.6%
49.21	4.101	1.25	7.5%	13.5%	17.5%	21.0%	3.5%	5.1%	5.7%	6.5%
59.05	4.921	1.50	7.5%	13.0%	17.5%	20.5%	3.0%	4.4%	4.9%	5.4%



Tensolite

A **CARLISLE** Company

(8 7 7) 8 9 0 - 7 4 8 3

(9 0 4) 8 2 9 - 3 4 4 7 (f a x)

T e n s o l i t e . c o m