



OKAYA Electric America, Inc.

SPECIFICATIONS

DRAWING CODE _____

SAMPLE CODE _____

(This Code will be changed while mass production)

MASS PRODUCTION CODE _____

RHWXGAT-10x1WP-FLPU

Customer Approved
Date:

Sales Sign	QC Confirmed	Checked By	Designer

pproval for Specifications Only

This specification is subject to change without notice

pproval for Specifications and Sample



Phone: 219-477-4488
Fax: 219-477-4856
www.okaya.com

OKAYA ELECTRIC AMERICA
52 Marks Road, Suite 1
Valparaiso, Indiana 46383



Contents

1. SPECIFICATIONS

- 1.1 Features**
- 1.2 Mechanical Specifications**
- 1.3 Absolute Maximum Ratings**
- 1.4 DC Electrical Characteristics**
- 1.5 Optical Characteristics**
- 1.6 Backlight Characteristics**
- 1.7 Touch Panel Characteristics**

2. MODULE STRUCTURE

- 2.1 Counter Drawing**
- 2.2 Interface Pin Description**
- 2.3 Timing Characteristics**

3. QUALITY ASSURANCE SYSTEM

- 3.1 Quality Assurance Flow Chart**
- 3.2 Inspection Specification**

4. RELIABILITY TEST

- 4.1 Reliability Test Condition**

5. PRECAUTION RELATING PRODUCT HANDLING

- 5.1 Safety**
- 5.2 Handling**
- 5.3 Storage**
- 5.4 Terms of Warranty**

Appendix : LCM Drawing.
LCM Packaging Specifications.



1. SPECIFICATIONS

1.1 Features

Item	Standard Value
Screen size(inch)	10.1(Diagonal)
Driver element	IPS
Resolution	1280* (R · G · B) * 800 Dots
Display mode	Normally Black, Transmissive
Touch panel	Projective Capacitive Touch Panel 5 Points touch
Surface treatment	Anti-Fingerprint Coating
Color arrangement	RGB-stripe
Weight	292.74(Typ.)
inversion	1+2line
Interface	LVDS
IC	HX8288*4 & HX8695*1
ROHS	THIS PRODUCT CONFORMS THE ROHS OF OKAYA

1.2 Mechanical Specifications

Item	Standard Value	Unit
Outline Dimension	254.96(W) * 173.6 (L) * 7.4 (H)	mm

LCD panel

Item	Standard Value	Unit
Active Area	216.96 (W) * 135.60 (L)	mm

Note : For detailed information please refer to LCM drawing



1.3 Absolute Maximum Ratings

Item	Symbol	Condition	Min.	Max.	Unit
Digital Supply Voltage	VDD	-	-0.3	+3.9	V
TFT Gate on voltage	VGH	-	-0.3	+42	V
TFT Gate off voltage	VGL	-	-19	+0.3	V
TFT Gate voltage	VGH-VGL	-	+12	+40	
Analog power supply voltage	AVDD	-	-0.3	+14	V
Operating Temperature	T _{OP}	-	-20	+70	°C
Storage Temperature	T _{ST}	-	-30	+80	°C
Storage Humidity	H _D	T _a < 60 °C	20	90	%RH

Note 1: The absolute maximum rating values of this product are not allowed to be exceeded at any times. Should a module be used with any of the absolute maximum ratings exceeded, the characteristics of the module may not be recovered, or in an extreme case, the module may be permanently destroyed.

1.4 DC Electrical Characteristics

Item	Symbol	Condition	Min.	Typ.	Max.	Unit
Digital Supply Voltage	VDD	-	-	3.3	-	
Analog power supply voltage	AVDD	-	8.0	8.2	8.4	V
TFT Gate on voltage	VGH	-	21.7	22.0	22.3	V
TFT Gate off voltage	VGL	-	-7.3	-7.0	-6.7	V
TFT Common electrode voltage	VCOM	-	2.7	3.0	3.3	V
Input logic high voltage	VIH	-	0.8*VDD	-	VDD	V
Input logic low voltage	VIL	-	0	-	0.2*VDD	V
Supply Current	IDD	VDD=3.3V Pattern= Picture*4	-	100	150	mA

Note 1: Be sure to apply VDD and V_{GL} to the LCD first, and then apply V_{GH}.

Note 2: VDD setting should match the signals output voltage (VIH / VIL) of customer's system board.

Note 3: Typical VCOM is only a reference value, it must be optimized according to each LCM. Be sure to use VR.

Note 4: Maximum current display.

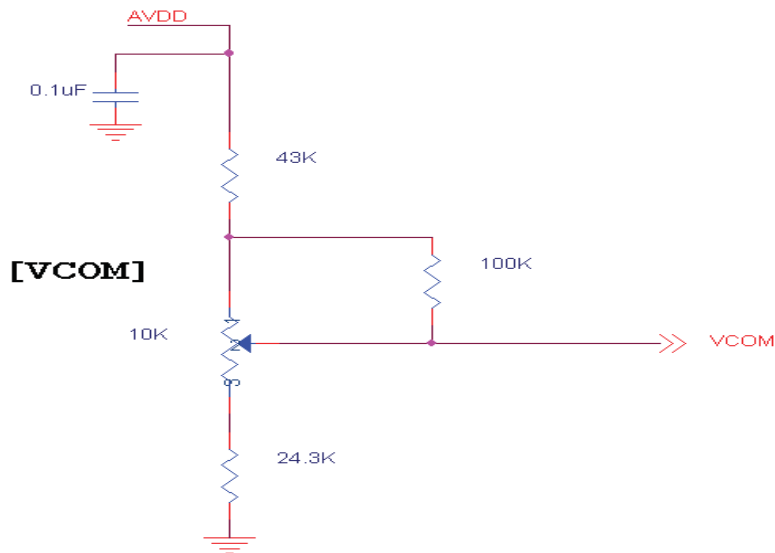

1.5 Optical Characteristics

TFT LCD Panel

Ta=25°C

Item	Symbol	Condition	Min.	Typ.	Max.	Unit	-	
Response time	Tr	-	-	10	20	ms	Note2	
	Tf		-	15	30			
Viewing angle	Top	ΘY+	CR ≥ 10	75	85	-	Deg.	Note4
	Bottom	ΘY-		75	85	-		
	Left	ΘX-		75	85	-		
	Right	ΘX+		75	85	-		
Contrast ratio	CR	IF=240mA	600	800	-	-	Note3	
Color of CIE Coordinate (With B/L)	White		X	0.26	0.31	0.36	-	Note1
	White		Y	0.31	0.36	0.41		
Average Brightness Pattern=white display	IV	IF=240mA	450	500	-	cd/m2	Note1	
Luminance uniformity	YU	IF=240mA	75	80	-	%	Note1	

Note1:

1 : $\Delta B = B(\min) / B(\max) \times 100\%$

2 : Measurement Condition for Optical Characteristics:

a : Environment: 25°C±5°C / 60±20%R.H , no wind , dark room below 10 Lux at typical lamp current and typical operating frequency.

b : Measurement Distance: 500 ± 50 mm , (θ= 0°)

c : Equipment: TOPCON BM-7 fast , (field 1°) , after 10 minutes operation.

d : The uncertainty of the C.I.E coordinate measurement ±0.01 , Average Brightness ± 4%

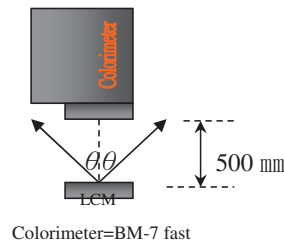

Note2: Definition of response time:

The output signals of photo detector are measured when the input signals are changed from “black” to “white”(falling time) and from “white” to “black”(rising time), respectively. The response time is defined as the time interval between the 10% and 90% of Amplitudes.

Refer to figure as below:

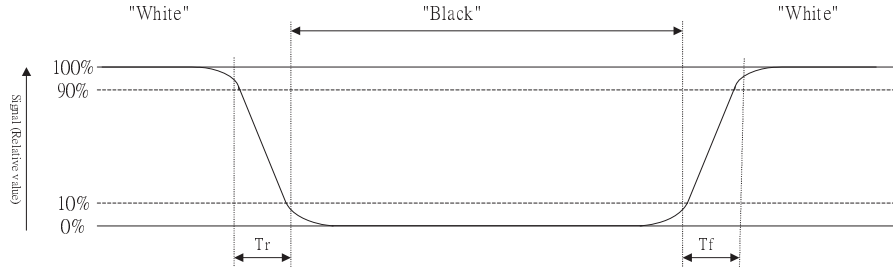

Note3: Definition of contrast ratio:

Contrast ratio is calculated with the following formula

$$\text{Contrast ratio (CR)} = \frac{\text{Photo detector output when LCD is at "White" state}}{\text{Photo detector output when LCD is at "Black" state}}$$

Note4: Definition of viewing angle:

Refer to figure as below:

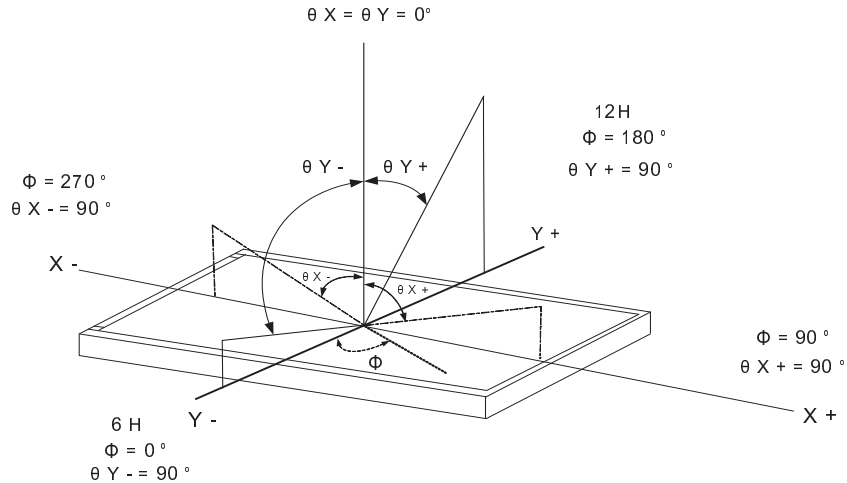



1.6 Backlight Characteristics

Maximum Ratings

Item	Symbol	Conditions	Min.	Typ.	Max.	Unit
Power Dissipation	Pd	-	-	4680	-	mW
LED Forward Current	IF	1 LED	-	-	70	mA
LED Reverse Voltage	VR	1 LED	-	-	5	V

Electrical / Optical Characteristics

Item	Symbol	Conditions	Min.	Typ.	Max.	Unit
Voltage for LED backlight	VF	-	16.8	(19.5)	21	V
Current for LED backlight	IF		200	240	280	mA
Color	White					

Other Description

Item	Conditions	Description
Life Time	Ta =25°C IF= 200mA	20000 hrs

Note: The "LED life time" is defined as the module brightness decrease to 50% original brightness at Ta=25°C and IF =200mA. The LED lifetime could be decreased if operating IF is larger than 200mA.



1.7 Touch Panel Characteristics

Features

Item	Standard Value
Touch Panel Size	10.1
Touch type	Projective capacitive touch panel
Input Method	Finger / 5 Points touch
Output Interface	USB
Response Time	≤ 25ms
Light Transparency	85% Min
Surface Hardness	7H(Pencil)

Mechanical Specifications

Item	Standard Value	Unit
Viewing Area	217.96 (W) * 136.6 (L)	mm

Absolute Maximum Ratings

Item	Symbol	Condition	Min.	Max.	Unit
Supply voltage	TPVDD	-	-0.3	+6.0	V
Operating Temperature	T _{OP}	-	-20	+70	°C
Storage Temperature	T _{ST}	-	-30	+80	°C

DC Electrical Characteristics

Item	Symbol	Condition	Min.	Typ.	Max.	Unit
Power Supply Voltage	TPVDD	-	-	5.0	-	V

Touch Panel IC Read/Write description & Register Mapping

Reference : Atmel Touch Driver Porting Reference Guide.



Interface Pin Description

CN2

Pin No.	Symbol	Function
1	TPVDD	Digital I/O Power Can be Set as TPVDD.
2	USB-D-	USB Differential Signal D-.
3	USB-D+	USB Differential Signal D+.
4	NC	Not Connection.
5	GND	Ground.
6	NC	Not Connection.



2. MODULE STRUCTURE

2.1 Counter Drawing

2.1.1 LCM Mechanical Diagram

* See Appendix



2.2 Interface Pin Description

A 40pin connector is used for the module electronics interface. The recommended model is FH52-40S-0.5SH manufactured by Vigor Conn.

Pin No.	Symbol	Description
1	VCOM	Common voltage
2	VDD	Digital power
3	VDD	Digital power
4	NC	Not connect
5	NC	Not connect
6	NC	Not connect
7	GND	Ground
8	RXIN0-	Negative LVDS differential data inputs
9	RXIN0+	Positive LVDS differential data inputs
10	GND	Ground
11	RXIN1-	Negative LVDS differential data inputs
12	RXIN1+	Positive LVDS differential data inputs
13	GND	Ground
14	RXIN2-	Negative LVDS differential data inputs
15	RXIN2+	Positive LVDS differential data inputs
16	GND	Ground
17	RXCLKIN-	Negative LVDS differential clock inputs
18	RXCLKIN+	Positive LVDS differential clock inputs
19	GND	Ground
20	RXIN3-	Negative LVDS differential data inputs
21	RXIN3+	Positive LVDS differential data inputs
22	GND	Ground
23	NC	Not connect
24	NC	Not connect
25	GND	Ground

Pin No.	Symbol	Description
26	NC	Not connect
27	LED_PWM	CABC controller signal output for backlight
28	NC	Not connect
29	AVDD	Power for Analog Circuit
30	GND	Ground
31	LED-	LED Cathode
32	LED-	LED Cathode
33	NC	Not connect
34	NC	Not connect
35	VGL	Gate OFF Voltage
36	GND	Ground
37	CABC_EN	CABC Enable Input. High Voltage: Enable; Low Voltage or open: Disable
38	VGH	Gate ON Voltage
39	LED+	LED Anode
40	LED+	LED Anode

Note: LED_PWM is used to adjust backlight brightness

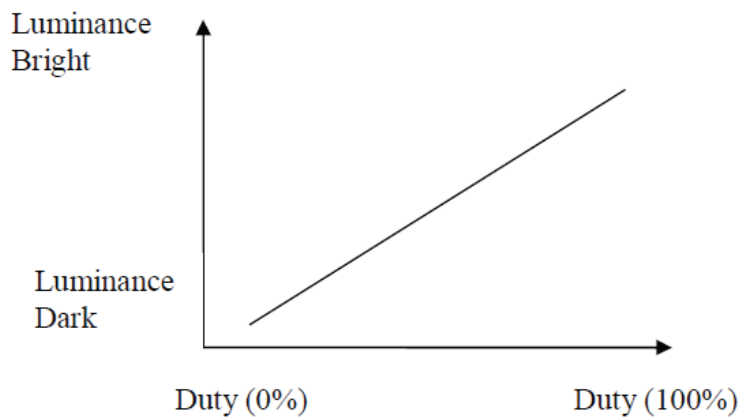

2.3 Timing Characteristics

2.3.1 POWER ON/OFF SEQUENCE

a. Power on:

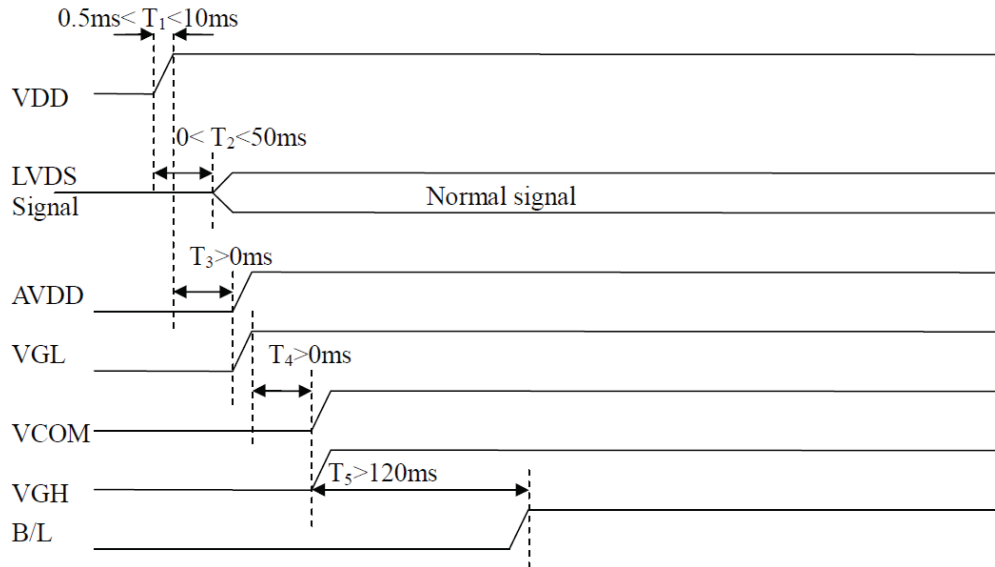

b. Power off:

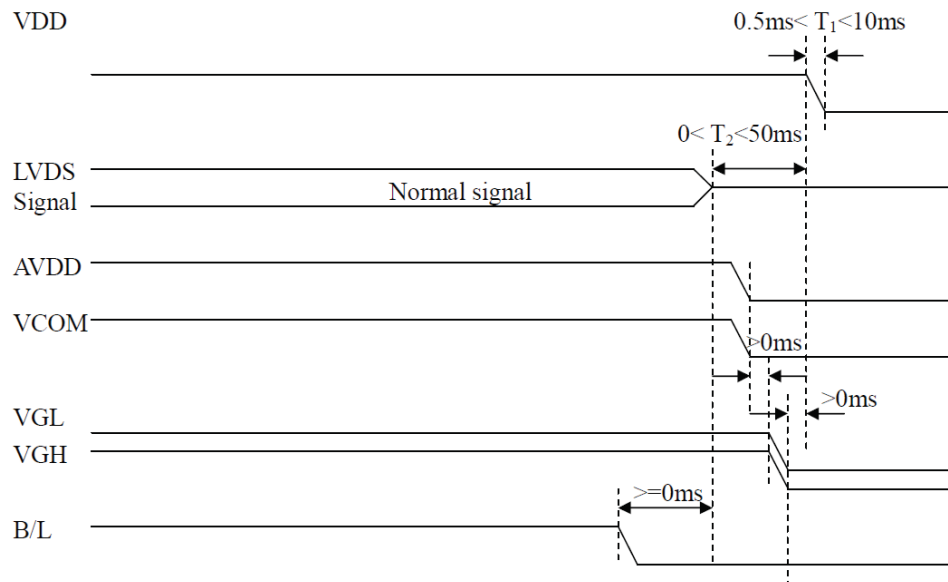

2.3.2 LVDS Signal Timing Characteristics AC Electrical Characteristics

Parameter	Symbol	Values			Unit	Remark
		Min.	Typ.	Max.		
LVDS Differential input high Threshold voltage	R_{xVTH}	-	-	+100	mV	$R_{xVCM}=1.2$ V
LVDS Differential input low Threshold voltage	R_{xVTL}	-100	-	-	mV	
LVDS Differential input common mode voltage	R_{xVCM}	0.7	-	1.6	V	
LVDS Differential voltage	$ V_{ID} $	200	-	600	mV	

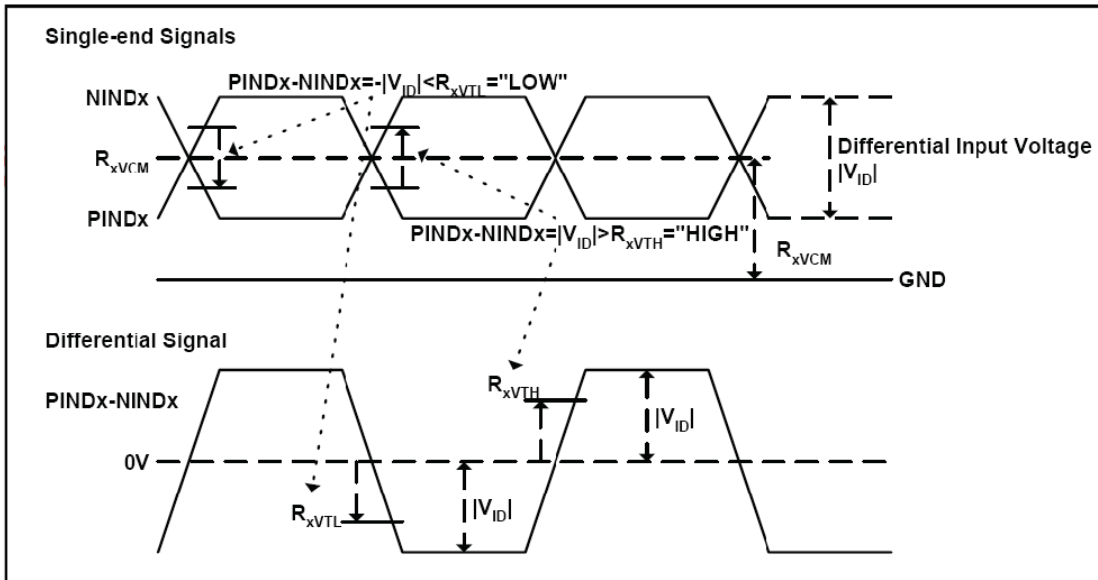

Timing Table

Item	Symbol	Values			Unit	Remark
		Min.	Typ.	Max.		
Clock Frequency	1/Tc	68.9	71.1	73.4	MHz	Frame rate =60Hz
Horizontal display area	t _{HD}	1280			Tc	
HS period time	t _H	1410	1440	1470	Tc	
HS Width +Back Porch +Front Porch	t _{HW} + t _{HBP} +t _{HFP}	130	160	190	Tc	
Vertical display area	t _{VD}	800			t _H	
VS period time	t _V	815	823	833	t _H	
VS Width +Back Porch +Front Porch	t _{VW} + t _{VBP} +t _{VFP}	15	23	33	t _H	

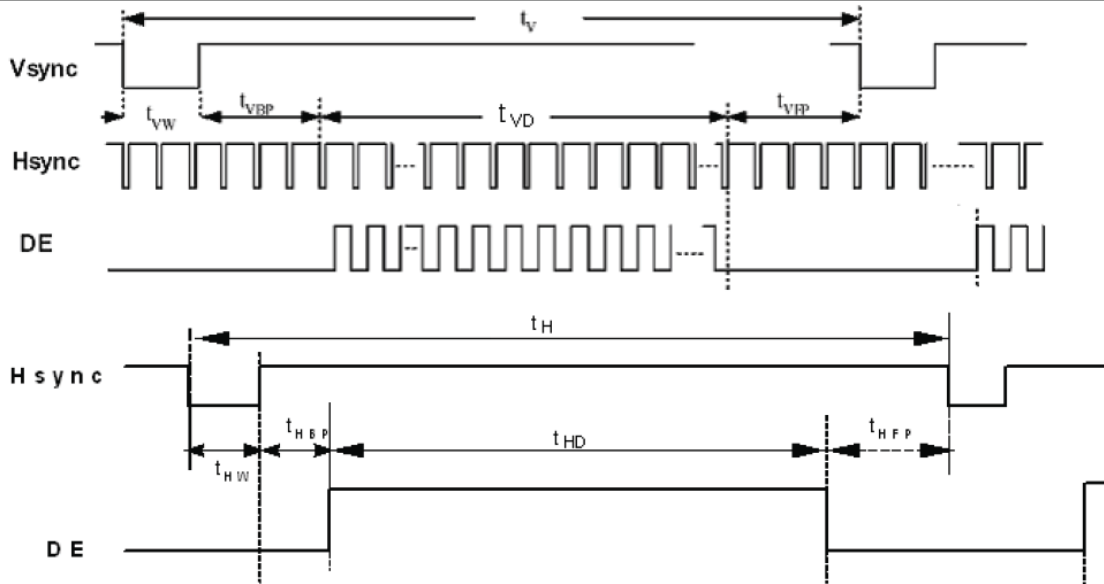

LVDS Data Input Format

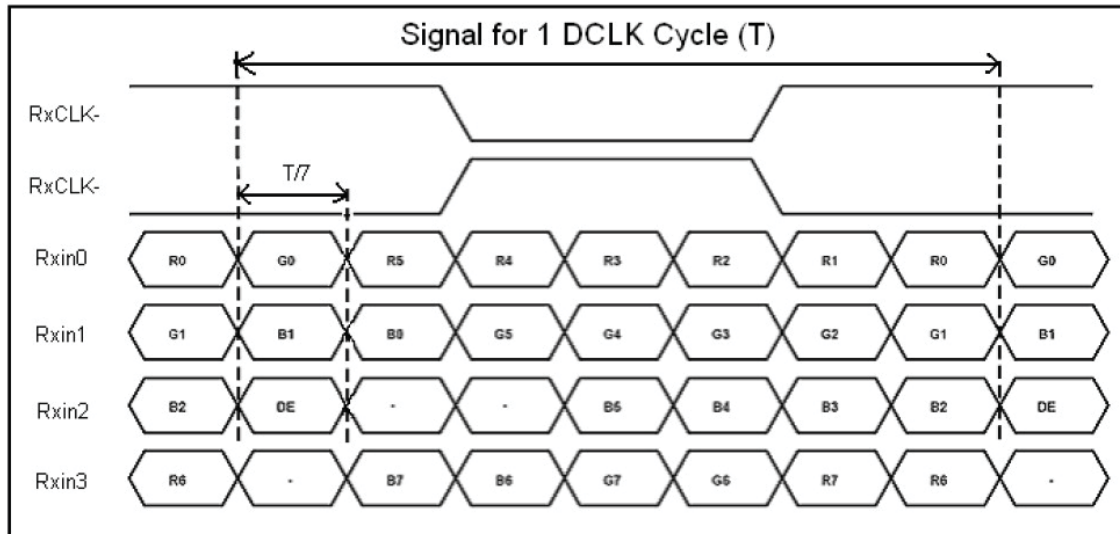



3. QUALITY ASSURANCE SYSTEM

3.1 Quality Assurance Flow Chart

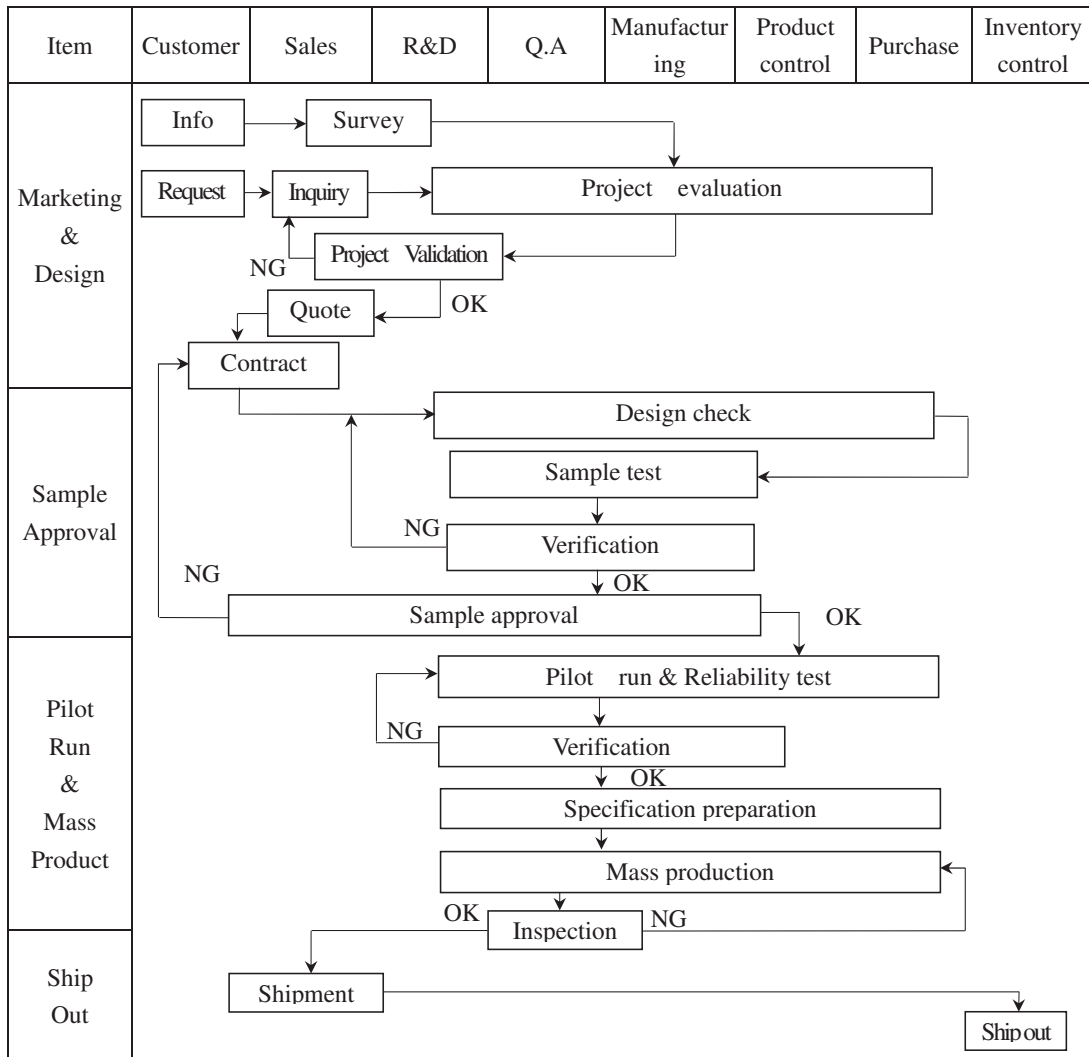

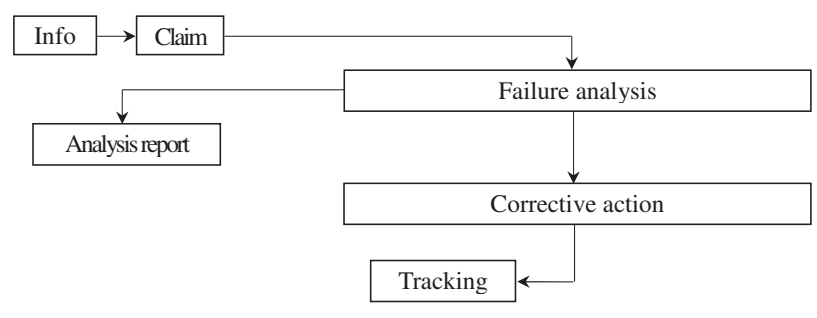
Item	Customer	Sales	R&D	Q.A	Manufacturing	Product control	Purchase	Inventory control
Sales Service	 <pre> graph TD Info[Info] --> Claim[Claim] Claim --> FA[Failure analysis] Claim --> AR[Analysis report] FA --> CA[Corrective action] CA --> Tracking[Tracking] </pre>							
Q.A Activity	1. ISO 9001 Maintenance Activities 3. Equipment calibration 5. Standardization Management				2. Process improvement proposal 4. Education And Training Activities			

3.2. Inspection Specification

- ◆Scope : The document shall be applied to TFT-LCD Module for 3.5" ~10" (Ver.B01).
- ◆Inspection Standard : MIL-STD-105E Table Normal Inspection Single Sampling Level II.
- ◆Equipment : Gauge 、MIL-STD 、Powertip Tester 、Sample
- ◆Defect Level : Major Defect AQL : 0.4 ; Minor Defect AQL : 1.5
- ◆OUT Going Defect Level : Sampling.
- ◆Standard of the product appearance test :

a. Manner of appearance test :

- (1). The test best be under 20W×2 fluorescent light , and distance of view must be at 30 cm.
- (2). The test direction is base on about around 45° of vertical line.

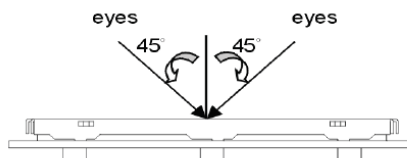

(3). Definition of area.

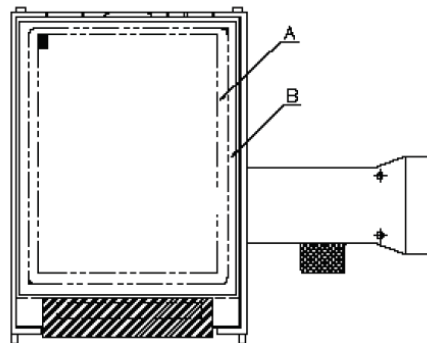

A area : viewing area

B area : Outside of viewing area

(4). Standard of inspection : (Unit : mm)

◆Specification For TFT-LCD Module 3.5" ~10" :

(Ver.B01)

NO	Item	Criterion	Level												
01	Product condition	1. 1 The part number is inconsistent with work order of production.	Major												
		1. 2 Mixed product types.	Major												
		1. 3 Assembled in inverse direction.	Major												
02	Quantity	2. 1 The quantity is inconsistent with work order of production.	Major												
03	Outline dimension	3. 1 Product dimension and structure must conform to structure diagram.	Major												
04	Electrical Testing	4. 1 Missing line character and icon.	Major												
		4. 2 No function or no display.	Major												
		4. 3 Display malfunction.	Major												
		4. 4 LCD viewing angle defect.	Major												
		4. 5 Current consumption exceeds product specifications.	Major												
05	<p>Dot defect (Bright dot 、 Dark dot)</p> <p>On -display</p>	<table border="1" data-bbox="634 1205 1179 1444"> <thead> <tr> <th colspan="2">Item</th> <th>Acceptance (Q'ty)</th> </tr> </thead> <tbody> <tr> <td rowspan="4">Dot Defect</td> <td>Bright Dot</td> <td>≦ 4</td> </tr> <tr> <td>Dark Dot</td> <td>≦ 5</td> </tr> <tr> <td>Joint Dot</td> <td>≦ 3</td> </tr> <tr> <td>Total</td> <td>≦ 7</td> </tr> </tbody> </table> <p>5. 1 Inspection pattern : full white , full black , Red , Green and blue screens. 5. 2 It is defined as dot defect if defect area > 1/2 dot. 5. 3 The distance between two dot defect ≧ 5 mm.</p>	Item		Acceptance (Q'ty)	Dot Defect	Bright Dot	≦ 4	Dark Dot	≦ 5	Joint Dot	≦ 3	Total	≦ 7	Minor
Item		Acceptance (Q'ty)													
Dot Defect	Bright Dot	≦ 4													
	Dark Dot	≦ 5													
	Joint Dot	≦ 3													
	Total	≦ 7													

◆Specification For TFT-LCD Module 3.5" ~10" :

(Ver.B01)

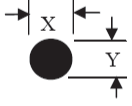
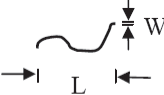
NO	Item	Criterion	Level																																				
06	<p>Black or white dot、scratch、contamination</p> <p>Round type</p>  <p>$\Phi = (x + y) / 2$</p> <p>Line type</p> 	<p>6.1 Round type (Non-display or display) :</p> <table border="1" data-bbox="613 495 1203 814"> <thead> <tr> <th rowspan="2">Dimension (diameter : Φ)</th> <th colspan="2">Acceptance (Q'ty)</th> </tr> <tr> <th>A area</th> <th>B area</th> </tr> </thead> <tbody> <tr> <td>$\Phi \leq 0.25$</td> <td>Ignore</td> <td rowspan="4">Ignore</td> </tr> <tr> <td>$0.25 < \Phi \leq 0.50$</td> <td>5</td> </tr> <tr> <td>$\Phi > 0.50$</td> <td>0</td> </tr> <tr> <td>Total</td> <td>5</td> </tr> </tbody> </table> <p>6.2 Line type(Non-display or display) :</p> <table border="1" data-bbox="591 905 1226 1264"> <thead> <tr> <th rowspan="2">Length (L)</th> <th rowspan="2">Width (W)</th> <th colspan="2">Acceptance (Q'ty)</th> </tr> <tr> <th>A area</th> <th>B area</th> </tr> </thead> <tbody> <tr> <td>---</td> <td>$W \leq 0.03$</td> <td>Ignore</td> <td rowspan="5">Ignore</td> </tr> <tr> <td>$L \leq 10.0$</td> <td>$0.03 < W \leq 0.05$</td> <td>4</td> </tr> <tr> <td>$L \leq 5.0$</td> <td>$0.05 < W \leq 0.10$</td> <td>2</td> </tr> <tr> <td>---</td> <td>$W > 0.10$</td> <td>As round type</td> </tr> <tr> <td colspan="2">Total</td> <td>5</td> </tr> </tbody> </table>	Dimension (diameter : Φ)	Acceptance (Q'ty)		A area	B area	$\Phi \leq 0.25$	Ignore	Ignore	$0.25 < \Phi \leq 0.50$	5	$\Phi > 0.50$	0	Total	5	Length (L)	Width (W)	Acceptance (Q'ty)		A area	B area	---	$W \leq 0.03$	Ignore	Ignore	$L \leq 10.0$	$0.03 < W \leq 0.05$	4	$L \leq 5.0$	$0.05 < W \leq 0.10$	2	---	$W > 0.10$	As round type	Total		5	Minor
Dimension (diameter : Φ)	Acceptance (Q'ty)																																						
	A area	B area																																					
$\Phi \leq 0.25$	Ignore	Ignore																																					
$0.25 < \Phi \leq 0.50$	5																																						
$\Phi > 0.50$	0																																						
Total	5																																						
Length (L)	Width (W)	Acceptance (Q'ty)																																					
		A area	B area																																				
---	$W \leq 0.03$	Ignore	Ignore																																				
$L \leq 10.0$	$0.03 < W \leq 0.05$	4																																					
$L \leq 5.0$	$0.05 < W \leq 0.10$	2																																					
---	$W > 0.10$	As round type																																					
Total		5																																					
07	Polarizer Bubble	<table border="1" data-bbox="586 1316 1232 1640"> <thead> <tr> <th rowspan="2">Dimension (diameter : Φ)</th> <th colspan="2">Acceptance (Q'ty)</th> </tr> <tr> <th>A area</th> <th>B area</th> </tr> </thead> <tbody> <tr> <td>$\Phi \leq 0.25$</td> <td>Ignore</td> <td rowspan="5">Ignore</td> </tr> <tr> <td>$0.25 < \Phi \leq 0.50$</td> <td>4</td> </tr> <tr> <td>$0.50 < \Phi \leq 0.80$</td> <td>1</td> </tr> <tr> <td>$\Phi > 0.80$</td> <td>0</td> </tr> <tr> <td>Total</td> <td>5</td> </tr> </tbody> </table>	Dimension (diameter : Φ)	Acceptance (Q'ty)		A area	B area	$\Phi \leq 0.25$	Ignore	Ignore	$0.25 < \Phi \leq 0.50$	4	$0.50 < \Phi \leq 0.80$	1	$\Phi > 0.80$	0	Total	5	Minor																				
Dimension (diameter : Φ)	Acceptance (Q'ty)																																						
	A area	B area																																					
$\Phi \leq 0.25$	Ignore	Ignore																																					
$0.25 < \Phi \leq 0.50$	4																																						
$0.50 < \Phi \leq 0.80$	1																																						
$\Phi > 0.80$	0																																						
Total	5																																						

◆Specification For TFT-LCD Module 3.5" ~10" :

(Ver.B01)

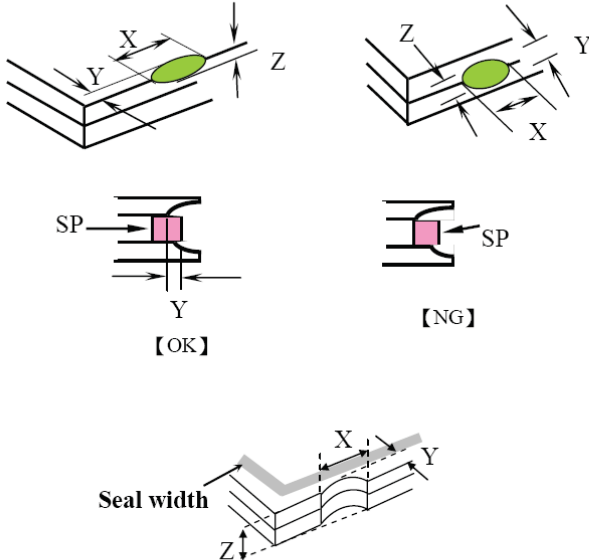
NO	Item	Criterion	Level						
08	The crack of glass	<p>Symbols :</p> <p>X : The length of crack Z : The thickness of crack t : The thickness of glass</p> <p>Y : The width of crack. W : terminal length a : LCD side length</p>	Minor						
		<p>8.1 General glass chip :</p> <p>8.1.1 Chip on panel surface and crack between panels:</p>  <table border="1" data-bbox="613 1381 1239 1612"> <thead> <tr> <th>X</th> <th>Y</th> <th>Z</th> </tr> </thead> <tbody> <tr> <td>$\leq a$</td> <td>Crack can't enter viewing area</td> <td>$\leq 1/2 t$</td> </tr> <tr> <td>$\leq a$</td> <td>Crack can't exceed the half of SP width.</td> <td>$1/2 t < Z \leq 2 t$</td> </tr> </tbody> </table>		X	Y	Z	$\leq a$	Crack can't enter viewing area	$\leq 1/2 t$
X	Y	Z							
$\leq a$	Crack can't enter viewing area	$\leq 1/2 t$							
$\leq a$	Crack can't exceed the half of SP width.	$1/2 t < Z \leq 2 t$							

◆Specification For TFT-LCD Module 3.5" ~10" :

(Ver.B01)

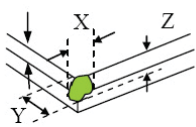
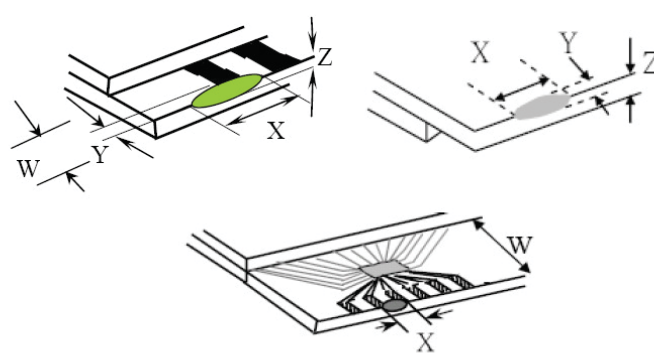
NO	Item	Criterion	Level									
08	The crack of glass	<p>Symbols :</p> <p>X : The length of crack Y : The width of crack. Z : The thickness of crack W : terminal length t : The thickness of glass a : LCD side length</p> <hr/> <p>8.1.2 Corner crack :</p>  <table border="1" data-bbox="597 756 1226 987"> <thead> <tr> <th>X</th> <th>Y</th> <th>Z</th> </tr> </thead> <tbody> <tr> <td>$\leq 1/5 a$</td> <td>Crack can't enter viewing area</td> <td>$Z \leq 1/2 t$</td> </tr> <tr> <td>$\leq 1/5 a$</td> <td>Crack can't exceed the half of SP width.</td> <td>$1/2 t < Z \leq 2 t$</td> </tr> </tbody> </table>	X	Y	Z	$\leq 1/5 a$	Crack can't enter viewing area	$Z \leq 1/2 t$	$\leq 1/5 a$	Crack can't exceed the half of SP width.	$1/2 t < Z \leq 2 t$	Minor
		X	Y	Z								
$\leq 1/5 a$	Crack can't enter viewing area	$Z \leq 1/2 t$										
$\leq 1/5 a$	Crack can't exceed the half of SP width.	$1/2 t < Z \leq 2 t$										
<p>8.2 Protrusion over terminal :</p> <p>8.2.1 Chip on electrode pad :</p>  <table border="1" data-bbox="625 1480 1234 1617"> <thead> <tr> <th></th> <th>X</th> <th>Y</th> <th>Z</th> </tr> </thead> <tbody> <tr> <td>Front</td> <td>$\leq a$</td> <td>$\leq 1/2 W$</td> <td>$\leq t$</td> </tr> <tr> <td>Back</td> <td>$\leq a$</td> <td>$\leq W$</td> <td>$\leq 1/2 t$</td> </tr> </tbody> </table>		X	Y	Z	Front	$\leq a$	$\leq 1/2 W$	$\leq t$	Back	$\leq a$	$\leq W$	$\leq 1/2 t$
	X	Y	Z									
Front	$\leq a$	$\leq 1/2 W$	$\leq t$									
Back	$\leq a$	$\leq W$	$\leq 1/2 t$									

◆Specification For TFT-LCD Module 3.5" ~10" :

(Ver.B01)

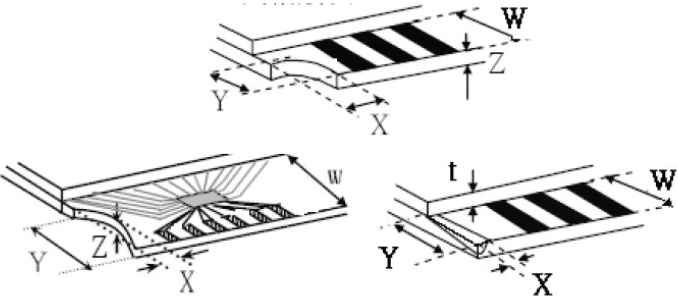
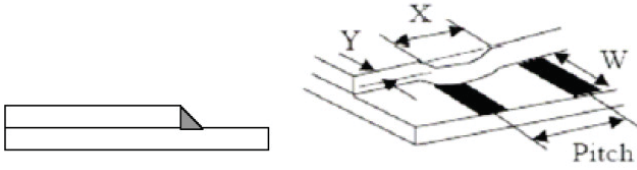
NO	Item	Criterion	Level												
08	The crack of glass	<p>Symbols :</p> <p>X : The length of crack Y : The width of crack. Z : The thickness of crack W : terminal length t : The thickness of glass a : LCD side length</p> <hr/> <p>8.2.2 Non-conductive portion :</p>  <table border="1" data-bbox="682 919 1174 1045"> <thead> <tr> <th>X</th> <th>Y</th> <th>Z</th> </tr> </thead> <tbody> <tr> <td>$\leq 1/3 a$</td> <td>$\leq W$</td> <td>$\leq t$</td> </tr> </tbody> </table> <p>⊙ If the chipped area touches the ITO terminal, over 2/3 of the ITO must remain and be inspected according to electrode terminal specifications.</p> <p>8.2.3 Glass remain :</p>  <table border="1" data-bbox="620 1528 1159 1642"> <thead> <tr> <th>X</th> <th>Y</th> <th>Z</th> </tr> </thead> <tbody> <tr> <td>$\leq a$</td> <td>$\leq 1/3 W$</td> <td>$\leq t$</td> </tr> </tbody> </table>	X	Y	Z	$\leq 1/3 a$	$\leq W$	$\leq t$	X	Y	Z	$\leq a$	$\leq 1/3 W$	$\leq t$	Minor
X	Y	Z													
$\leq 1/3 a$	$\leq W$	$\leq t$													
X	Y	Z													
$\leq a$	$\leq 1/3 W$	$\leq t$													



5. PRECAUTION RELATING PRODUCT HANDLING

5.1 SAFETY

- 5.1.1 If the LCD panel breaks , be careful not to get the liquid crystal to touch your skin.
- 5.1.2 If the liquid crystal touches your skin or clothes , please wash it off immediately by using soap and water.

5.2 HANDLING

- 5.2.1 Avoid any strong mechanical shock which can break the glass.
- 5.2.2 Avoid static electricity which can damage the CMOS LSI—When working with the module , be sure to ground your body and any electrical equipment you may be using.
- 5.2.3 Do not remove the panel or frame from the module.
- 5.2.4 The polarizing plate of the display is very fragile. So , please handle it very carefully ,do not touch , push or rub the exposed polarizing with anything harder than an HB pencil lead (glass , tweezers , etc.)
- 5.2.5 Do not wipe the polarizing plate with a dry cloth , as it may easily scratch the surface of plate.
- 5.2.6 Do not touch the display area with bare hands , this will stain the display area.
- 5.2.7 Do not use ketonics solvent & aromatic solvent. Use with a soft cloth soaked with a cleaning naphtha solvent.
- 5.2.8 To control temperature and time of soldering is $320\pm 10^{\circ}\text{C}$ and 3-5 sec.
- 5.2.9 To avoid liquid (include organic solvent) stained on LCM .

5.3 STORAGE

- 5.3.1 Store the panel or module in a dark place where the temperature is $25^{\circ}\text{C} \pm 5^{\circ}\text{C}$ and the humidity is below 65% RH.
- 5.3.2 Do not place the module near organics solvents or corrosive gases.
- 5.3.3 Do not crush , shake , or jolt the module.

5.4 TERMS OF WARRANTY

- 5.4.1 Applicable warrant period
The period is within thirteen months since the date of shipping out under normal using and storage conditions.
- 5.4.2 Unaccepted responsibility
This product has been manufactured to your company's specification as a part for use in your company's general electronic products. It is guaranteed to perform according to delivery specifications. For any other use apart from general electronic equipment , we cannot take responsibility if the product is used in nuclear power control equipment , aerospace equipment , fire and security systems or any other applications in which there is a direct risk to human life and where extremely high levels of reliability are required.

Ver.002	Documents NO. <input type="text"/>	<h2 style="text-align: center;">LCM包裝規格書</h2> <h3 style="text-align: center;">LCM Packaging Specifications</h3> <p style="text-align: center;">(For Tray)</p>	Approve	Check	Contact
			Oliver	Stone	Kevin

1. 包裝材料規格表 (Packaging Material) : (per carton)

No.	Item	Model	Dimensions (mm)	1Pcs Weight	Quantity	Total Weight
1	成品 (LCM)	RHWXGAT-10x1WP-FLPU	254.96 X 173.6	0.4735	24	11.364
2	多層薄膜(1)POF	OTFILM0BA03ABA	—————	—————	3	—————
3	TRAY 盤 (2)Tray	TY00000000394	517 X 377 X 18.8	0.2	12	2.4
4	內盒(3)Product Box	BX00000000071	558 X 393 X 68	0.6	3	1.8
5	保利龍板(4)Polylon board	OTPLB00PL08ABA	550 X 393 X 20	0.0284	2	0.0568
6	外紙箱(5)Carton	BX57041027CCBA	570 X 410 X 265	1.4208	1	1.4208
7	舒美墊(6)EPE	OTFOAMEP0004BA	333X 218 X 15	0.027	3	0.081
8						
9						

2. 一整箱總重量 (Total LCD Weight in carton) : 17.12 Kg±10%

3. 單箱數量規格表 (Packaging Specifications and Quantity) :

(1)LCD quantity per box : no per tray	2	x no of tray	4	=	8
(2)Total LCD quantity in carton : quantity per box	8	x no of boxes	3	=	24

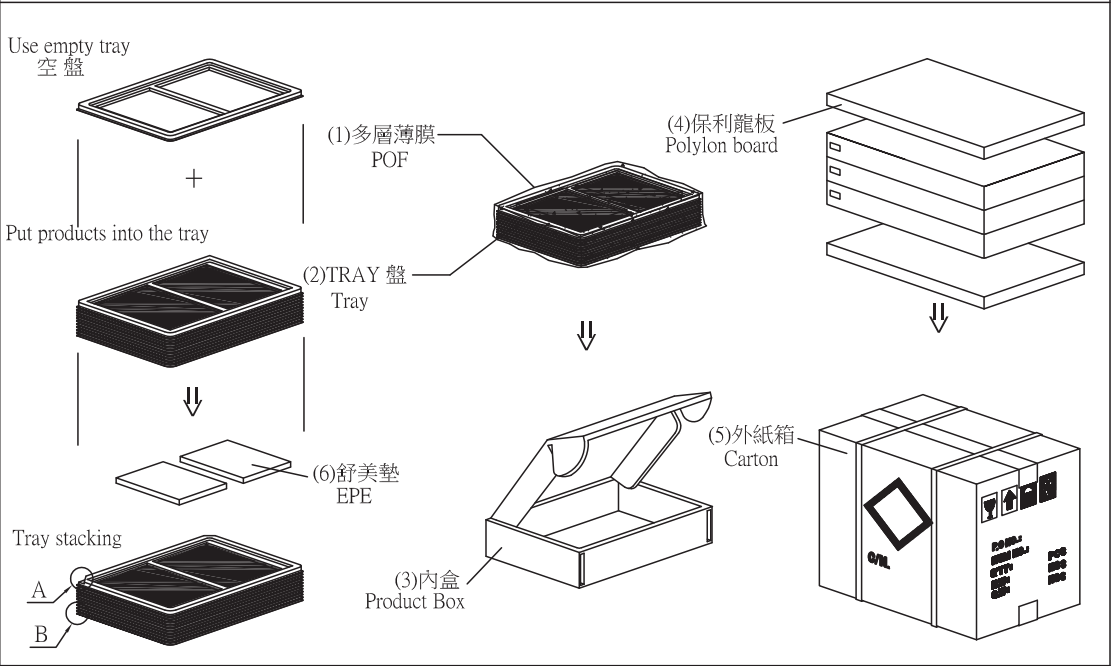

特 記 事 項 (REMARK)

<p>4. TRAY盤相疊時,需旋轉180度,請詳見B視圖 Rotate tray 180 degrees and place on top of stack. Check the tray stack using Fig. B.</p>	<p>5. 最上層產品上放置EPE(舒美墊)</p>	
---	----------------------------	--