

AccuStar® Electronic Clinometer



- +/-60° total sensing range
- CE certified
- Analog, digital and PWM outputs
- High accuracy / low cost
- Lightweight and compact
- Rugged plastic housing

DESCRIPTION

The **AccuStar® Electronic Clinometer** is an extremely accurate angle measurement device that produces an output signal which corresponds directly to the magnitude and direction of angular displacement. Measuring just 2 inches in diameter, this compact and affordable sensor is ideal where high accuracy measurements are required in space restrictive applications.

The heart of the system is a patented, capacitance-based sensor with no moving parts. When rotated about its sensitive axis, this unique sensor provides an exceedingly linear variation in capacitance, which is electronically converted into angular data. The sensor and low-power CMOS electronics are encased in a rugged plastic housing ready to install as a system component or as a stand-alone device.



The AccuStar® mounts easily onto any vertical surface using just two #6 or M3.5 screws. The slot at the base allows for fine adjustment of the zero angle position after installation. With a choice of analog, ratiometric, digital (PWM) or serial output models, the AccuStar® is designed for easy installation and integration.

Also see our other models, **AccuStar® IP-66** (voltage or 2-wire current output, IP-66 rating), **AngleStar® Protractor System** (AccuStar® with digital readout) and **AngleStar® DP-45** (handheld digital protractor).

Measurement Specialties, Inc. (NASDAQ MEAS) offers many other types of sensors. Data sheets can be downloaded from our web site at: <http://www.meas-spec.com/datasheets.aspx>

*MEAS acquired Schaevitz Sensors and the **Schaevitz®** trademark in 2000.*

FEATURES

- ±60° total sensing range
- Unipolar or bipolar DC operation
- Rugged plastic housing
- 18" flying lead termination

APPLICATIONS

- Wheel alignment
- Construction equipment
- Antenna position
- Robotics

AccuStar® Electronic Clinometer

PERFORMANCE SPECIFICATIONS (COMMON)

ELECTRICAL		ENVIRONMENTAL/MECHANICAL	
Total range	±60°	Operating temperature range	-30° to +65°C
Linear range	±45°	Storage temperature range	-55° to +65°C
Linearity		Temp. coefficient of null	0.008° / °C
Null to ±10°	0.1°	Temp. coefficient of scale factor	0.1% / °C
±10° to 45°	±1% of reading	EMC	
±45° to 60°	Monotonic	Emissions	EN55022 (CISPR 22) Limit B
Threshold	0.001°	Radiated immunity	IEC 801-3 Level 3 10V/m
Null repeatability	0.05°	Burst transients	IEC 801-4 Level 3 (2kV)
Cross axis error	<1% up to 45°	Electrostatic discharge	IEC 801-2 Level 2 (8 kV air, 6kV contact)
Time constant	0.3 seconds	Conducted RF	MIL-STD 461D, CS114, Curve 2
Frequency response	0.5Hz @ -3db	Cable	18" flying leads, PTFE insulation
RF susceptibility	<±2%		

Notes:

All values are nominal unless otherwise noted!

Dimensions are in inch [mm] unless otherwise noted

DIMENSIONS (COMMON)

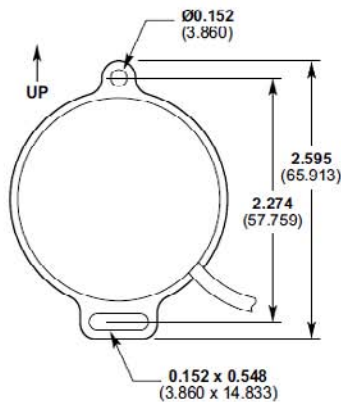

Vertical Flange Mount

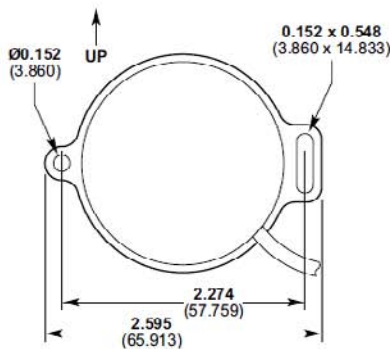

Horizontal Flange Mount

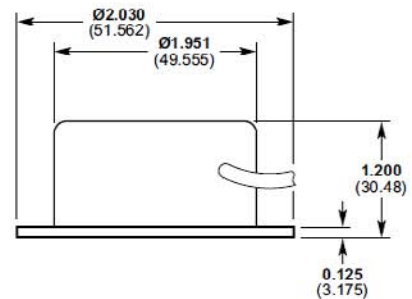

AccuStar® Electronic Clinometer

RATIOMETRIC OUTPUT MODEL

The Ratiometric clinometer is a signal conditioned sensor that has been designed to operate like a potentiometer. This is a three wire device: power; power ground; and signal. The signal is referenced to power ground. A regulated power supply is required since the output is supply dependent. The midscale output, zero degrees, is 1/2 the supply voltage while the scale factor is also supply dependent. With its low power consumption, 0.5 mA, this device is ideal for battery supplied applications. The Ratiometric clinometer was designed with EMI and ESD suppression circuitry on every line.

Output with +9VDC (nominal) input voltage

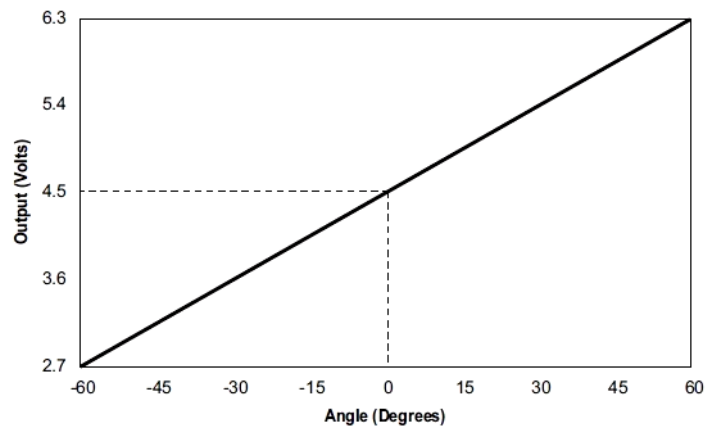

Circuit Block Diagram

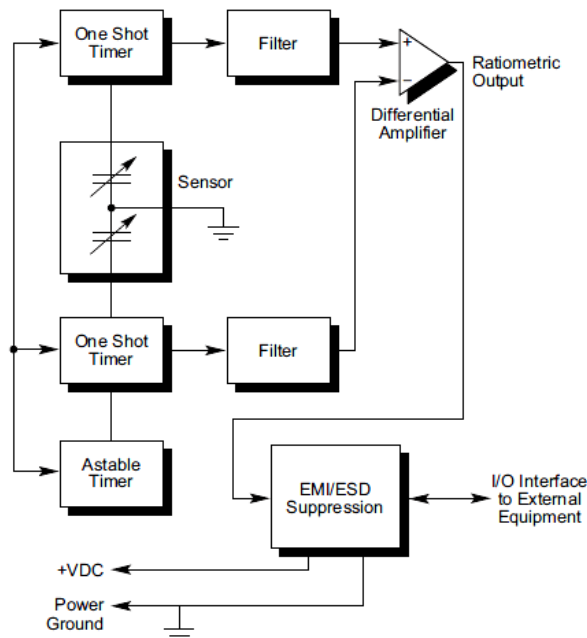

ELECTRICAL SPECIFICATIONS

Input voltage (nominal)	+9VDC
Input voltage range	+5 to +15VDC
Input current	0.5mA
Scale factor (@ +9VDC input)	30mV / degree, ±10%
Load resistance (min)	10kΩ
Level output (0°)	½ Vcc
ELECTRICAL CONNECTIONS	
Red	+ 5 to +15VDC (regulated)
Black	Power ground
Yellow	Signal output (referenced to power ground)

AccuStar® Electronic Clinometer

ANALOG OUTPUT MODEL

The Analog clinometer is a signal conditioned sensor which has been designed for dc voltage, bipolar operation. The clinometer requires a bipolar supply of ± 8 to ± 15 VDC and delivers an output of ± 3.6 VDC. This device is internally regulated for various applications. The output scale is fixed at a nominal 60mV per degree not dependent on the supply voltage. The Analog clinometer has full EMI and ESD suppression circuitry on every line.

Analog Output

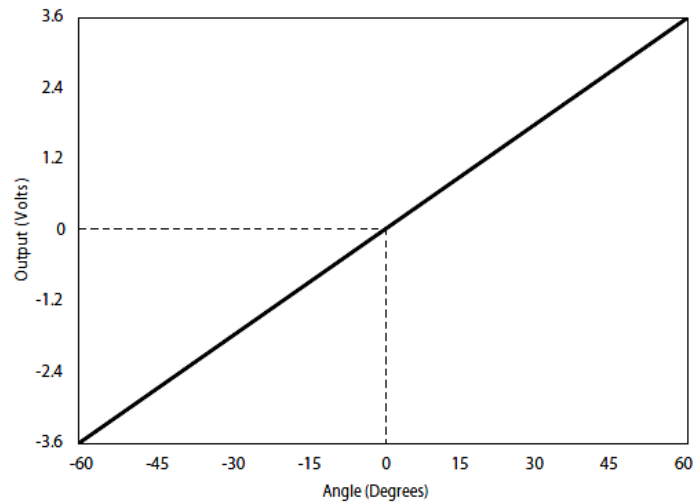

Circuit Block Diagram

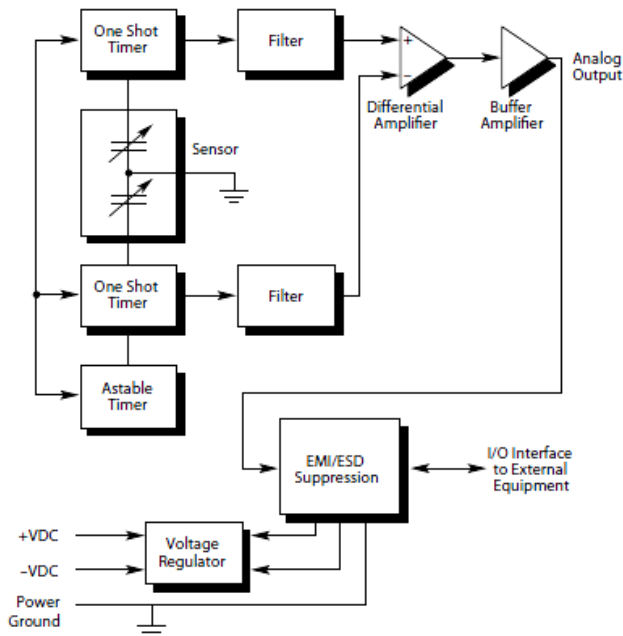

ELECTRICAL SPECIFICATIONS

Input voltage (nominal)	± 12 VDC
Input voltage range	± 8 to ± 15 VDC
Input current	5mA / supply
Scale factor (@ +9VDC input)	60mV / degree, $\pm 10\%$
Load resistance (min)	10k Ω
Level output (0°)	0 VDC

ELECTRICAL CONNECTIONS

Red	+ 8 to +15VDC
Black	Power ground
Gray	- 8 to -15VDC
Blue	Signal output (referenced to power ground)

AccuStar® Electronic Clinometer

DIGITAL PULSE WIDTH OUTPUT MODEL

The Digital Pulse Width clinometer is a signal conditioned sensor which resolves the angle of tilt to pulses, the length of which are directly proportional to the angle. When a trigger pulse is received on trigger 1 or trigger 2 a pulse is sent out on the corresponding PW1 or PW2 line. Comparing the length of the two pulses determines the angle of the sensor. Triggering both lines together allows the user to read Delta PW which is the difference of PW1 and PW2. The polarity line will tell the user if the sensor is tilted clockwise, or counterclockwise. The Digital Pulse Width clinometer was designed with EMI and ESD suppression circuitry on every line.

Pulse width output format

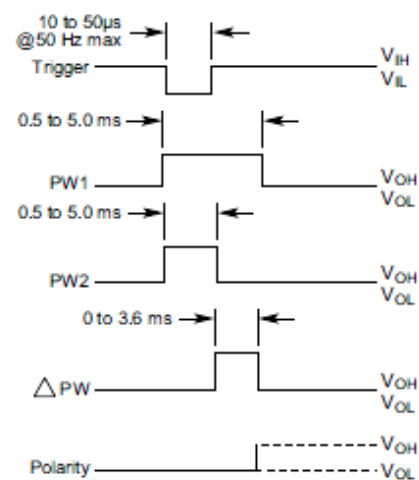

V_{IH} (max) 5.3V
 V_{IH} (min) 3.0V
 V_{IL} (max) 0.8V
 V_{OH} (min) 4.95V
 V_{OL} (max) 0.05V
Polarity updated on falling edge of ΔPW
Polarity high CW, low CCW

Voltage output is TTL compatible. Each output can drive one low power Schottky or multiple CMOS devices.

Circuit Block Diagram

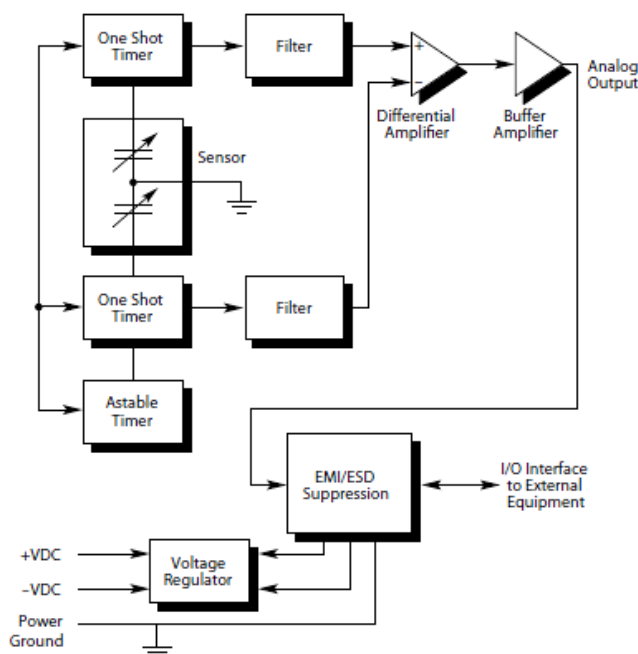

ELECTRICAL SPECIFICATIONS

Input voltage (nominal)	+12VDC
Input voltage range	+8 to +15VDC
Input current	5mA
Scale factor (@ +9VDC input)	60μsec / degree, ±10%
Load resistance (min)	10kΩ
Level output (0°)	DPW = 0 sec / PW1 = PW2
Trigger pulse (CE version)	10 to 50μsec @50Hz max
PW1 / PW2	0.5 to 5msec
ΔPW	0 to 3.6msec
Polarity	High = CW Low = CCW
ELECTRICAL CONNECTIONS	
Red	+ 8 to +15VDC
Black	Power ground
Brown	Trigger 1
Blue	Trigger 2
Green	Polarity
Gray	PW1
White	PW2
Yellow	ΔPW

AccuStar® Electronic Clinometer

SERIAL DATA OUTPUT MODEL

The Serial clinometer is a signal conditioned Sensor which resolves the angle of tilt to 16 bits of information plus a polarity bit. This device was designed to transmit data to a microcontroller or to an I/O card of a PC through a three wire interface which will work at both TTL and CMOS logic levels. Complete handshaking is used to eliminate timing and transmission problems. The standard version operates on a +5 VDC regulated power supply while an internally regulated version is available. The Serial clinometer was designed with EMI and ESD suppression circuitry on every line.

Serial data format

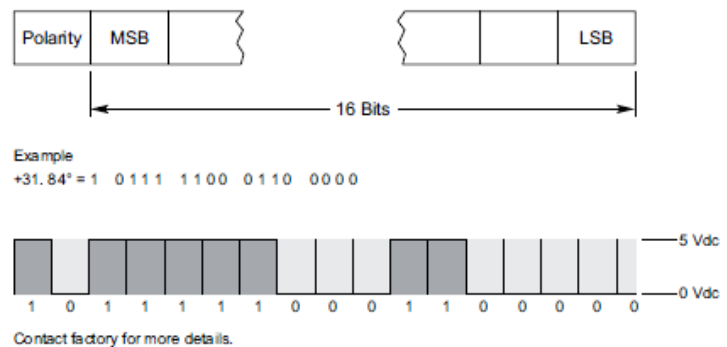

Circuit Block Diagram

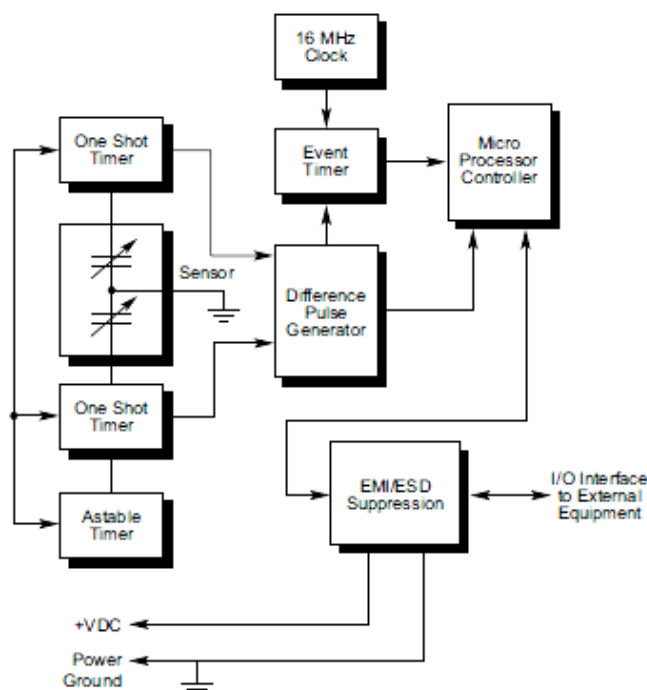

ELECTRICAL SPECIFICATIONS	
Input voltage (nominal)	+5VDC, ±5%
Input current	15mA
Scale factor	1000 counts/degree ±10%
Output	CMOS / TTL
Level output (0°)	0 counts
Binary range	16 bits plus 1 bit polarity (serial)
ELECTRICAL CONNECTIONS	
Red	+5VDC
Black	Power ground
Yellow	Data
White	Request / Hold
Gray	Ready / Wait

AccuStar® Electronic Clinometer

ORDERING INFORMATION

Model	Mounting Flange Orientation	Part Number
Ratiometric	Vertical	02110002-000
Ratiometric	Horizontal	02110102-000
Analog	Vertical	02111002-000
Analog	Horizontal	02111102-000
Digital	Vertical	02112002-000
Digital	Horizontal	02112102-000
Serial	Vertical	02113002-000
Serial	Horizontal	02113102-000