

MHR-V Series – Miniature Vented Case AC LVDT



- Vented case for submersed applications
- Operating pressure up to 10,000 PSI
- Operating temperature up to 392°F [200°C]
- Small size and low mass core
- High output signal
- Stroke ranges from ± 0.025 to ± 1 inch
- AC operation from 2kHz to 20kHz
- Stainless steel housing
- Imperial or metric threaded core

DESCRIPTION

The **MHR-V Series** LVDTs are a variant of the legendary MHR Series. The MHR-V is specifically designed for submersion in inert gas, mineral oil, and other non-aggressive oils (*consult factory for medium compatibility*) under pressures up to 10,000 PSI [700 bars].

With a diameter of just 3/8 inch [9.5mm], the MHR-V Series allow precision measurements in space restrictive installations at temperatures up to 392°F [200°C]. The extremely lightweight core makes the MHR-V an excellent choice for applications where excessive core weight could influence the motion of the measurand; with less inertia, accurate measurements at higher displacement speeds are easier to achieve. The lightweight core also reduces mechanical stresses and helps preserve the structural integrity of the core actuation assembly.

The high output sensitivity resulting from the close electrical coupling between the coil and core provides an excellent signal to displacement ratio for maximum positional resolution and for interfacing with practically all signal conditioners, conditioning circuits, and most OEM ASICs. The magnetic stainless steel housing provides electromagnetic and electrostatic shielding.

Available in a variety of stroke ranges from ± 0.025 to ± 1 inch, the MHR-V is compatible with the full line of Measurement Specialties LVDT signal conditioners.

Measurement Specialties, Inc. (NASDAQ MEAS) offers many other types of sensors and signal conditioners. Data sheets can be downloaded from our web site at: <http://www.meas-spec.com/datasheets.aspx>

MEAS acquired Schaevitz Sensors and the **Schaevitz™** trademark in 2000.

FEATURES

- Compact size
- Up to 10,000 PSI equipressure operation
- 392°F [200°C] continuous operation
- $\pm 0.25\%$ linearity (@100% stroke)
- Stainless steel case
- Calibration certificate supplied with each unit

APPLICATIONS

- Immersion applications (oils, inert gasses)
- Subsea Oil & Gas equipment
- Down-hole tools and oil drilling equipment
- Hydrostatic test chambers
- Hydraulic spool valve feedback
- Automotive transmission servo testing

MHR-V Series – Miniature Vented Case AC LVDT

PERFORMANCE SPECIFICATIONS

ELECTRICAL SPECIFICATIONS (common)						
Input voltage	3 VRMS sine wave					
Input frequency	2kHz to 20kHz					
Test frequency	2.5kHz (standard)					
ELECTRICAL SPECIFICATIONS @ 10kHz (recommended operation)						
Parameter	MHR-V 025	MHR-V 050	MHR-V 100	MHR-V 250	MHR-V 500	MHR-V 1000
Stroke range	±0.025 [±0.64]	±0.05 [±1.27]	±0.10 [±2.54]	±0.25 [±6.35]	±0.5 [±12.7]	±1 [±25.4]
Sensitivity, V/V/inch [mV/V/mm]	8.10 [319]	3.15 [124]	2.80 [110]	2.07 [81.5]	1.96 [77.2]	0.77 [30.3]
Output at stroke ends, mV/V (*)	202.5	157.5	280	517.5	980	770
Phase shift	+21°	+8°	+5°	+7°	+7°	-1°
Input impedance (PRIMARY)	238Ω	419Ω	400Ω	345Ω	264Ω	155Ω
Output impedance (SECONDARY)	485Ω	154Ω	200Ω	420Ω	810Ω	450Ω
Non-linearity	±% of FR					
@ 50% stroke	0.15	0.15	0.15	0.15	0.15	0.20
@100% stroke (maximum)	0.25	0.25	0.25	0.25	0.25	0.25
@125% stroke	0.25	0.35	0.25	0.35	0.30 (**)	0.50
@150% stroke	0.30	0.50	0.30	0.50 (**)	0.75 (**)	/
Null voltage (max.)	0.5% of FSO					
ELECTRICAL SPECIFICATIONS @ 2.5kHz (standard calibration)						
Parameter	MHR-V 025	MHR-V 050	MHR-V 100	MHR-V 250	MHR-V 500	MHR-V 1000
Stroke range	±0.025 [±0.64]	±0.05 [±1.27]	±0.10 [±2.54]	±0.25 [±6.35]	±0.5 [±12.7]	±1 [±25.4]
Sensitivity, V/V/in [mV/V/mm]	4.36 [172]	2.55 [100]	2.40 [94]	1.73 [68]	1.60 [63]	0.70 [27]
Output at 100% stroke, mV/V (*)	109	127.5	240	432.5	800	700
Phase shift	+58°	+36°	+30°	+33°	+23°	+6°
Input impedance (PRIMARY)	116Ω	141Ω	135Ω	147Ω	145Ω	100Ω
Output impedance (SECONDARY)	286Ω	90Ω	125Ω	268Ω	445Ω	370Ω
Non-linearity	% of FR					
@ 50% stroke	0.15	0.15	0.15	0.15	0.15	0.20
@100% stroke (maximum)	0.25	0.25	0.25	0.25	0.25	0.25
@125% stroke	0.25	0.35	0.25	0.35	0.30 (**)	0.50
@150% stroke	0.30	0.50	0.30	0.50 (**)	0.75 (**)	/
Null voltage (max)	0.5% of FSO					
ENVIRONMENTAL SPECIFICATIONS & MATERIALS						
Operating temperature	-4°F to +392°F [-20°C to 200°C]					
Operating pressure	Up to 10,000 PSI [700 bars]; maximum slew rate 1,000 PSI [70 bars] per minute (***)					
Housing material	AISI 400 Series stainless steel					
Electrical connection	Six lead-wires, 32 AWG stranded plated Copper, PTFE insulated, 3 foot [1 meter] long					

Notes:

All values are nominal unless otherwise noted

Electrical specifications are for the test frequency indicated in the table

Dimensions are in inch [mm] unless otherwise noted

FR: Full Range is the stroke range, end to end; FR=2xS for ±S stroke range

FSO (Full Scale Output): Largest absolute value of the outputs measured at the ends of the range

(*) Unit for output at stroke ends is millivolt per volt of excitation (input voltage)

(**) Requires special reduced core length

(***) Do not increase or decrease pressure faster than 1,000 PSI [70 bars] per minute to avoid permanent damage

CAUTION

MHR-V Series – Miniature Vented Case AC LVDT

MECHANICAL SPECIFICATIONS

Parameter	MHR-V 025	MHR-V 050	MHR-V 100	MHR-V 250	MHR-V 500	MHR-V 1000
Body length "A"	0.660 [16.8]	0.815 [20.7]	0.990 [25.1]	1.850 [47.0]	3.300 [83.82]	5.600 [142.2]
Core length "B"	0.400 [10.2]	0.500 [12.7]	0.625 [15.9]	1.125 [28.6]	2.000 [50.8]	3.000 [76.2]
Housing vent hole diameter "C"	0.063 [1.60]	0.063 [1.60]	0.063 [1.60]	0.063 [1.60]	0.063 [1.60]	0.063 [1.60]
Vent hole spacing "D"	0.20 [5.1] to 0.28 [7.1]	0.27 [6.9]	0.33 [8.4]	0.46 [11.7]	0.825 [21.0]	0.80 [20.3]
Number of vent holes per row "E"	2	2	2	3	3	6
Number of hole rows around housing "F"	4	4	4	3	3	3
Body weight, oz [g]	0.18 [5]	0.21 [6]	0.21 [6]	0.32 [9]	0.60 [17]	0.92 [26]
Core weight, oz [g]	0.016 [0.5]	0.016 [0.5]	0.025 [0.7]	0.032 [0.9]	0.056 [1.6]	0.088 [2.5]

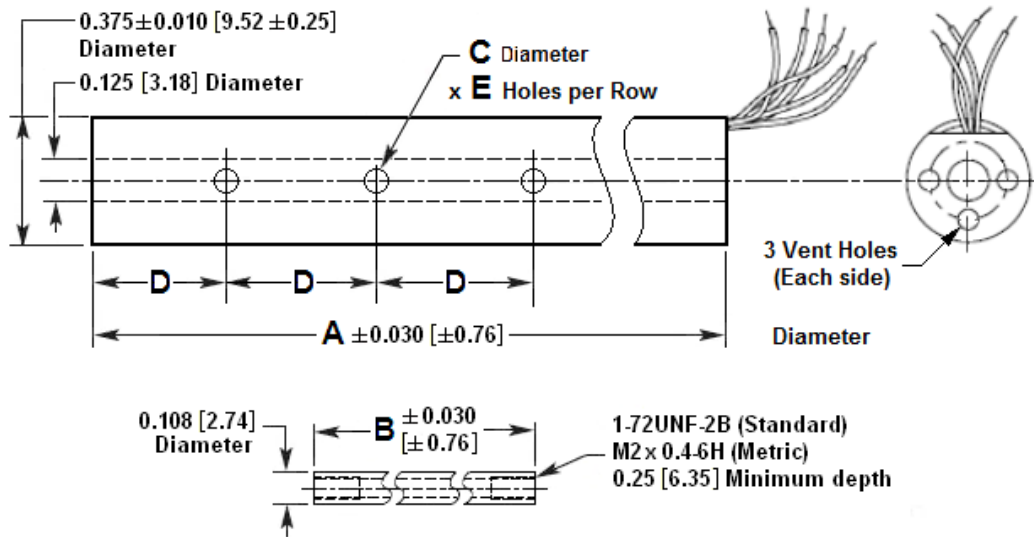

Dimensions are in inch [mm]

WIRING INFORMATION

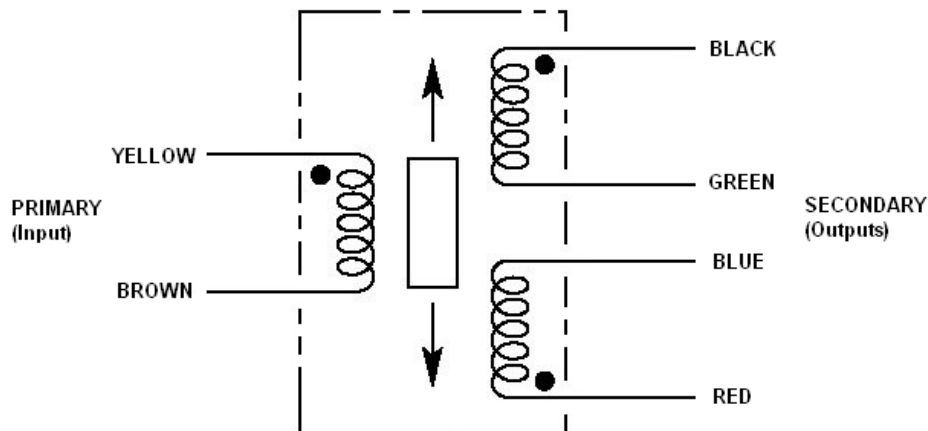

MHR-V Series – Miniature Vented Case AC LVDT

Connect Blue to Green for differential output

ORDERING INFORMATION

Description	Model	Part Number
±0.025 inch LVDT	MHR-V 025	02564407-000
±0.05 inch LVDT	MHR-V 050	02564408-000
±0.10 inch LVDT	MHR-V 100	02564409-000

Description	Model	Part Number
±0.25 inch LVDT	MHR-V 250	02564410-000
±0.5 inch LVDT	MHR-V 500	02564411-000
±1 inch LVDT	MHR-V 1000	02564412-000

OPTIONS AND ACCESSORIES

Metric threaded core (use base part numbers from above)	XXXXXXXX-006
Core connecting rod, 6 inches long, 1-72 threads	05282945-006
Core connecting rod, 12 inches long, 1-72 threads	05282945-012
Core connecting rod, 24 inches long, 1-72 threads	05282945-024
Core connecting rod, 36 inches long, 1-72 threads	05282945-036
Core connecting rod, 6 inches long, M2x0.4 metric threads	05282976-006
Core connecting rod, 12 inches long, M2x0.4 metric threads	05282976-012

Refer to our "[Accessories for LVDTs](#)" data sheet for our LVDT signal conditioning instrumentation and other accessories.

TECHNICAL CONTACT INFORMATION

NORTH AMERICA	EUROPE	ASIA
Measurement Specialties, Inc. 1000 Lucas Way Hampton, VA 23666 United States Phone: +1-800-745-8008 Fax: +1-757-766-4297 Email: sales@meas-spec.com Web: www.meas-spec.com	MEAS Deutschland GmbH Hauert 13 D-44227 Dortmund Germany Phone: +49-(0)231-9740-0 Fax: +49-(0)231-9740-20 Email: info.de@meas-spec.com Web: www.meas-spec.com	Measurement Specialties China Ltd. No. 26, Langshan Road High-tech Park (North) Nanshan District, Shenzhen 518057 China Phone: +86-755-33305088 Fax: +86-755-33305099 Email: info.cn@meas-spec.com Web: www.meas-spec.com

The information in this sheet has been carefully reviewed and is believed to be accurate; however, no responsibility is assumed for inaccuracies. Furthermore, this information does not convey to the purchaser of such devices any license under the patent rights to the manufacturer. Measurement Specialties, Inc. reserves the right to make changes without further notice to any product herein. Measurement Specialties, Inc. makes no warranty, representation or guarantee regarding the suitability of its product for any particular purpose, nor does Measurement Specialties, Inc. assume any liability arising out of the application or use of any product or circuit and specifically disclaims any and all liability, including without limitation consequential or incidental damages. Typical parameters can and do vary in different applications. All operating parameters must be validated for each customer application by customer's technical experts. Measurement Specialties, Inc. does not convey any license under its patent rights nor the rights of others.